

12THHAP

HYPER HIGH HEAD AUTO PRIME

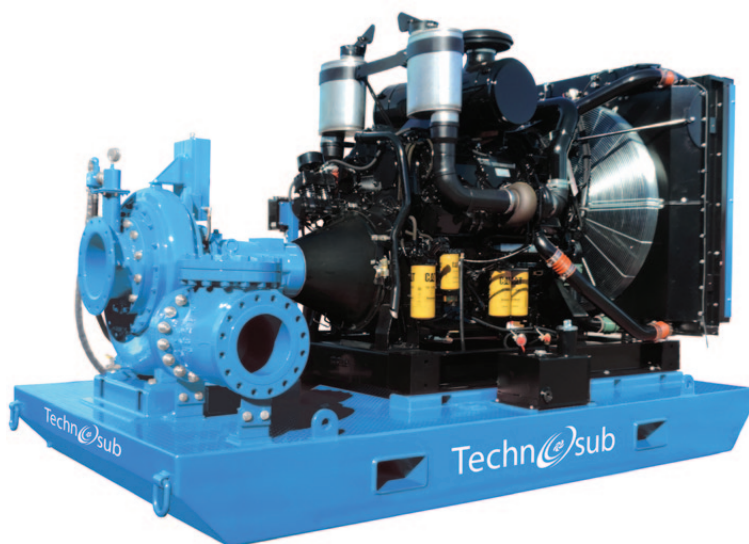

Technosub® High Performance High Pressure Auto Prime pumps are specifically designed to effectively handle a wide range of liquids in applications such as liquid transfer, wash down, fire protection, fracking and jetting where high heads and pressure are required.

Technosub THH Auto Prime pumps provide a dependable, highly efficient solution in a completely automatic priming pump.

The model 12THHAP is capable of achieving maximum flows of 7500 gpm (1700 m³/h) and maximum total head of 582' (177 m) with solids handling up to 2-1/2" (63 mm) in diameter.

The standard 12THHAP is powered by a water-cooled, 12-cylinder diesel engine. Alternative drives are available including natural gas as well as electric motors.

FEATURES

- Technosub's rugged, heavy duty pumps are engineered specifically for portable application
- Fully automatic priming system allows the pump to prime and re-prime while running
- Compressor-fed, venturi priming system provides rapid, reliable priming
- Fully guarded coupling
- Mechanical seal with biodegradable glycol quench allows the pump to start and run dry
- Non-return valve uses only a single moving part to allow full flow with minimal restriction
- Pump casings are hydrostatically tested to 50 psig (345 kPa) above the peak casing design pressure
- Standard engine control panel provides preset emergency shutdown protection and allows the addition of automatic level control
- Standard skid-mounted format with sled runners and pull bars, integral fuel tank, tie downs, lifting bail and fork pockets

OPTIONS

- Technosub's Environmental Box captures venturi blow by, separates and silences air exhaust and returns liquid to the pump suction.
- Fuel tanks for extended run times and/or remote location as required
- Highway trailer with integral fuel cell/chassis, lights, fenders, tie downs, lifting bail, front and rear jacks
- Trailer brakes can be offered as required
- Sound attenuated enclosure options
- Hose racks, accessory containers and other custom features available as required
- Wide range of suction and discharge fittings including Technosub's own "QD" Quick Disconnect fittings and accessories

Various motor sizes available pending operating point

12THHAP HYPER HIGH HEAD AUTO PRIME

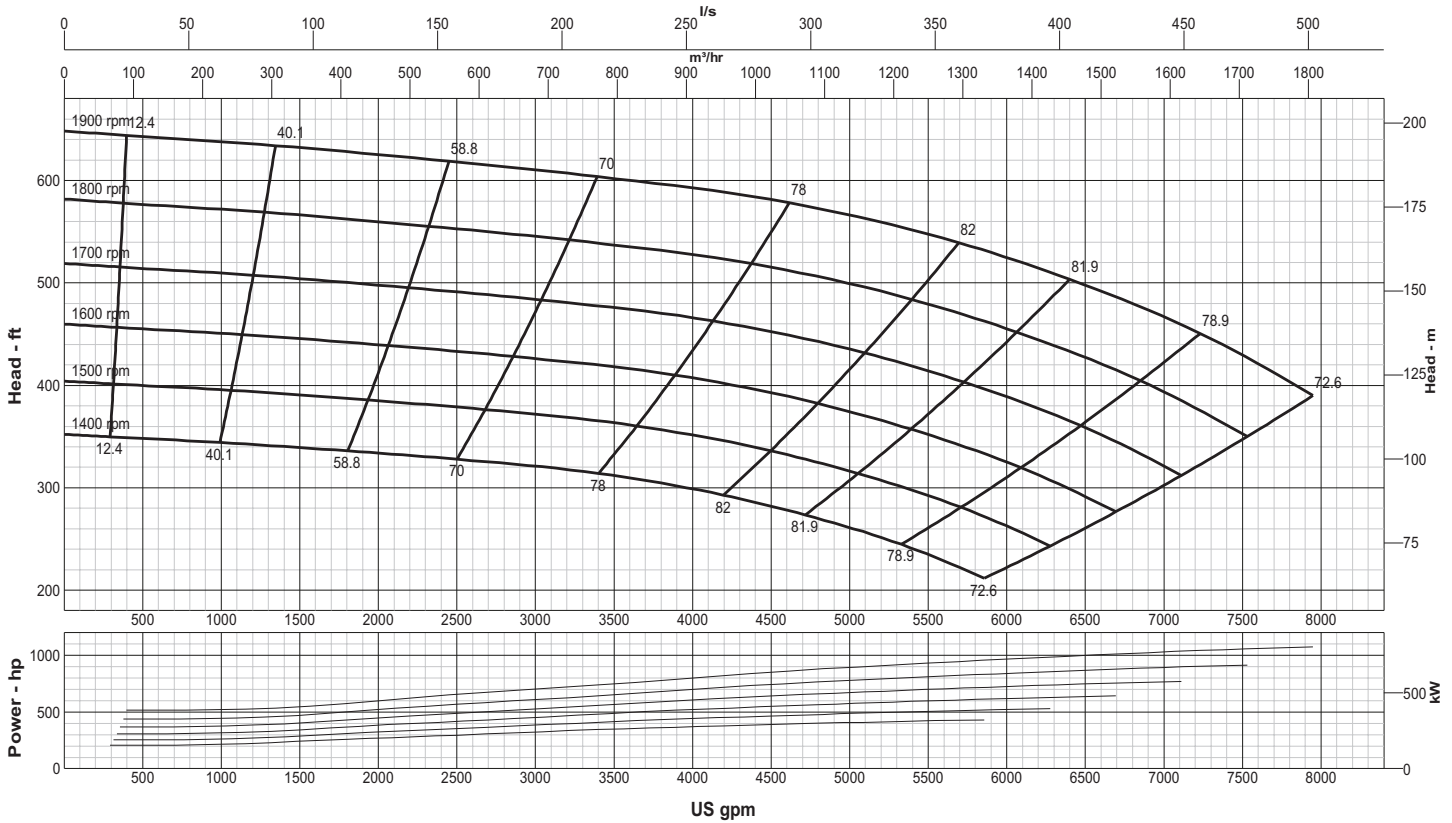
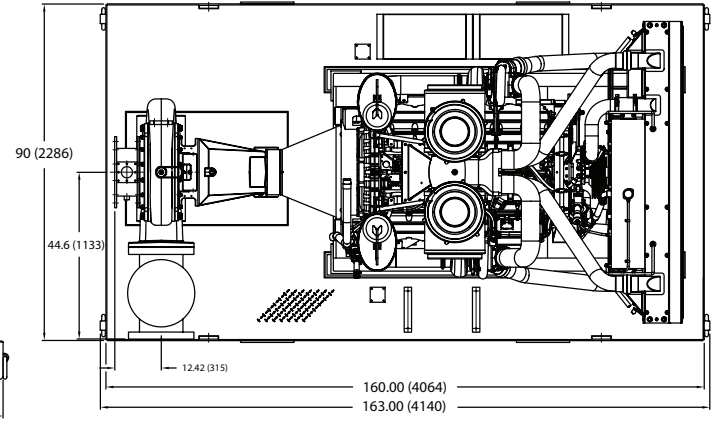
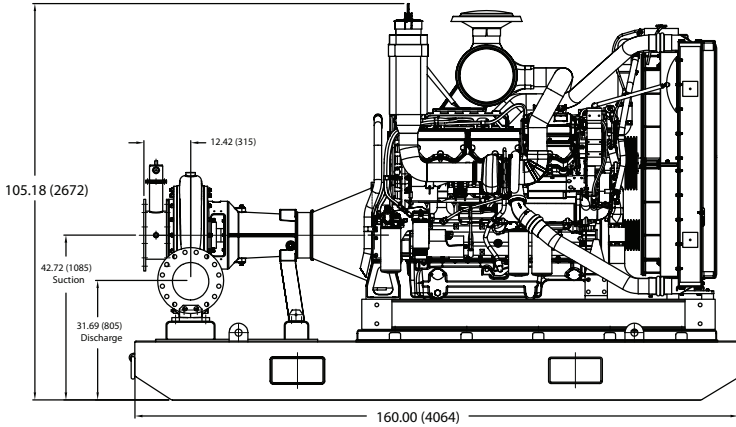

SPECIFICATIONS

- **Connections:** 12" x 10" (300 mm x 250 mm) ANSI Flanges
- **Maximum Pump Speed:** 1900 rpm
- **Maximum Flow:** 7950 gpm (1806 m³/h)
- **Maximum Head:** 648' (198m)
- **Maximum Static Priming Lift:** 28' (8.5 m)
- **Water Temperature Limit:** 160° F (70° C)
- **Solids Handling Capability:** 2.5" (63.5 mm)
- **Maximum Casing Pressure:** 300 psig (2068 kPa)
- **Fuel Cell:** 5 gal. Test Tank
- **Dry Weight:** 18 000 lbs
- **HP:** May vary, contact Sales Representative.

PUMP MATERIALS

- **Casing:** Cast Steel (CD4MCu is an option)
- **Impeller:** CD4MCu
- **Wear Rings:** 316 SS
- **Bearing Housing:** Cast Iron
- **Bearing Lubrication:** Grease
- **Shaft:** Steel
- **Shaft sleeve:** Stainless steel
- **Seal:** Silicon Carbide on Silicon Carbide
- **Chassis/Fuel Cell:** Steel
- **Non-Return Valve:** Steel

Specifications and illustrations are subject to revision without notice. Technosub is not liable for any consequential, incidental or indirect damages relating to these specifications.

1 819 797-3300

TECHNOSUB.NET

1156 Larivière avenue, Rouyn-Noranda QC Canada J9X 4K8

T 819 797-3300 F 819 797-3060 info@technosub.net

Technosub

INDUSTRIAL PUMPS
DEWATERING SOLUTIONS

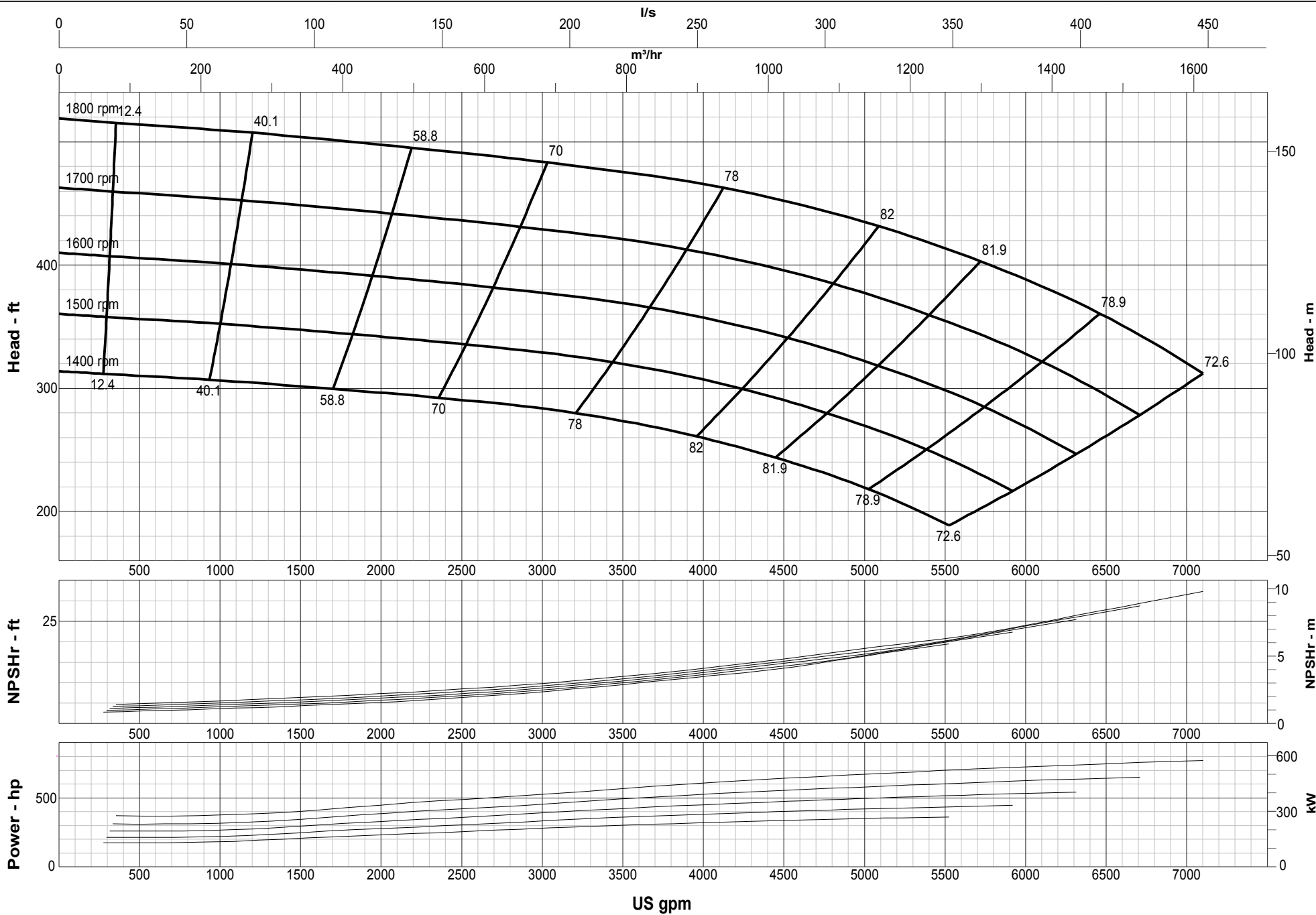

SPECIFICATIONS

Model size : 12THHAP
 Speed : 1400- 1800 rpm
 Dia : 20,75 in



1 819 797-3300
 TECHNOSUB.NET
 info@technosub.net