



Technosub® High Performance High Pressure Auto Prime pumps are specifically designed to effectively handle a wide range of liquids in applications such as liquid transfer, wash down, fire protection, fracking and jetting where high heads and pressure are required.

Technosub High Performance High Pressure Auto Prime pumps provide a dependable, highly efficient solution in a completely automatic priming pump.

The model 6THHAP is capable of achieving maximum flows of 1300 gpm (295 m³/h) and maximum total head of 606' (185 m) with solids handling up to 7/8" (22 mm) in diameter.

The standard 6THHAP is powered by a water-cooled, 6-cylinder diesel engine. Alternative drives are available, including other diesel engines or electric motor options.

FEATURES

- Technosub's rugged, heavy duty pumps are engineered specifically for portable application
- Fully automatic priming system allows the pump to prime and re-prime while running
- Compressor-fed, venturi priming system provides rapid, reliable priming
- Fully guarded coupling
- Mechanical seal with biodegradable glycol quench allows the pump to start and run dry
- Non-return valve uses only a single moving part to allow full flow with minimal restriction
- Pump casings are hydrostatically tested to 50 psig (345 kPa) above the peak casing design pressure
- Standard engine control panel provides preset emergency shutdown protection and allows the addition of automatic level control
- Standard skid-mounted format with sled runners and pull bars, integral fuel tank, tie downs, lifting bail and fork pockets

OPTIONS

- Technosub's Environmental Box captures venturi blow by, separates and silences air exhaust and returns liquid to the pump suction.
- Fuel tanks for extended run times and/or remote location as required
- Highway trailer with integral fuel cell/chassis, lights, fenders, tie downs, lifting bail, front and rear jacks
- Trailer brakes can be offered as required
- Sound attenuated enclosure options
- Hose racks, accessory containers and other custom features available as required
- Wide range of suction and discharge fittings including Technosub's own "QD" Quick Disconnect fittings and accessories

Various motor sizes available pending operating point

6THHAP HYPER HIGH HEAD AUTO PRIME

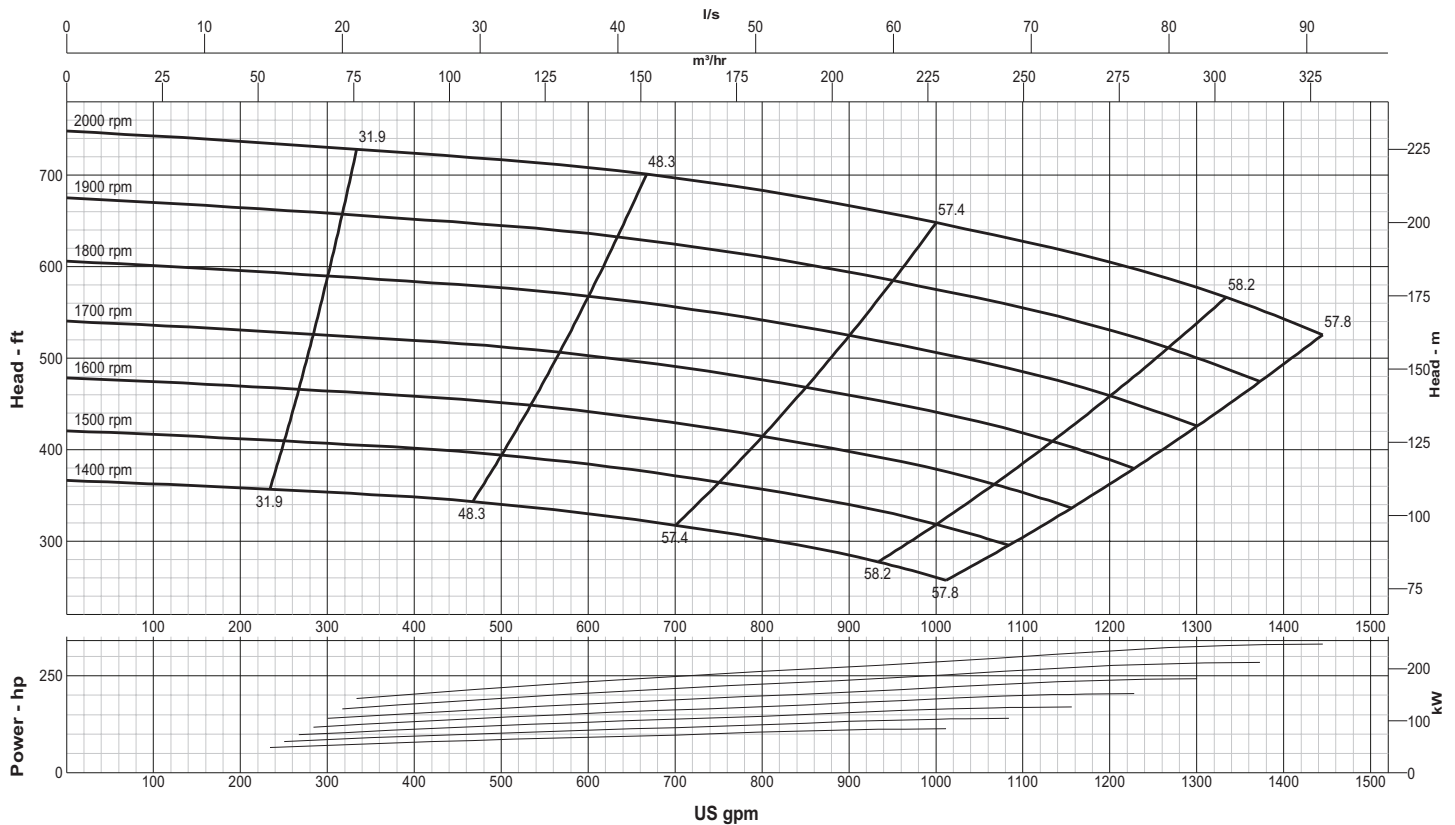
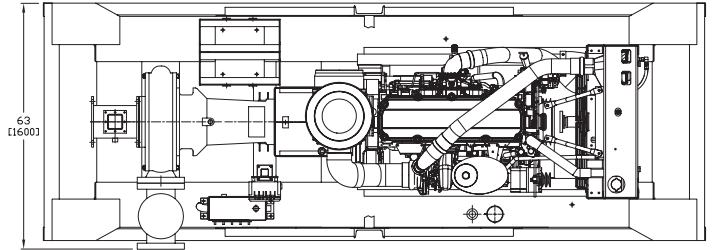
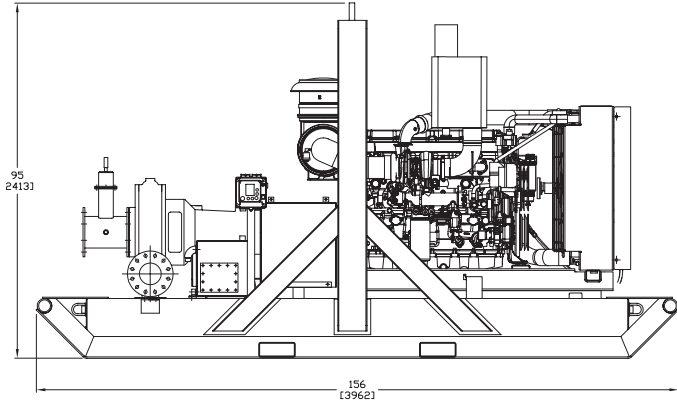

SPECIFICATIONS

- **Connections:** 6" x 4" (150 mm x 100 mm) ANSI Flanges
- **Maximum Pump Speed:** 2000 rpm
- **Maximum Flow:** 1440 gpm (327 m³/h)
- **Maximum Head:** 748' (228 m)
- **Maximum Static Priming Lift:** 28' (8.5 m)
- **Water Temperature Limit:** 160° F (70° C)
- **Solids Handling Capability:** 7/8" (22,2 mm)
- **Maximum Casing Pressure:** 300 psig (2068 kPa)
- **Fuel Cell:** 325 gallons (1230 liters)
- **Dry Weight:** 8700 lbs
- **HP:** May vary, contact Sales Representative.

PUMP MATERIALS

- **Casing:** Cast Steel (CD4MCu is an option)
- **Impeller:** CD4MCu
- **Bearing Housing:** Cast Iron
- **Bearing Lubrication:** Grease
- **Shaft:** Steel
- **Shaft Sleeve:** Stainless Steel
- **Seal:** Silicon Carbide on Silicon Carbide
- **Chassis/Fuel Cell:** Steel
- **Non-Return Valve:** Steel

Specifications and illustrations are subject to revision without notice. Technosub is not liable for any consequential, incidental or indirect damages relating to these specifications.

1 819 797-3300

TECHNOSUB.NET

1156 Larivière avenue, Rouyn-Noranda QC Canada J9X 4K8

T 819 797-3300 F 819 797-3060 info@technosub.net

Technosub

INDUSTRIAL PUMPS
DEWATERING SOLUTIONS

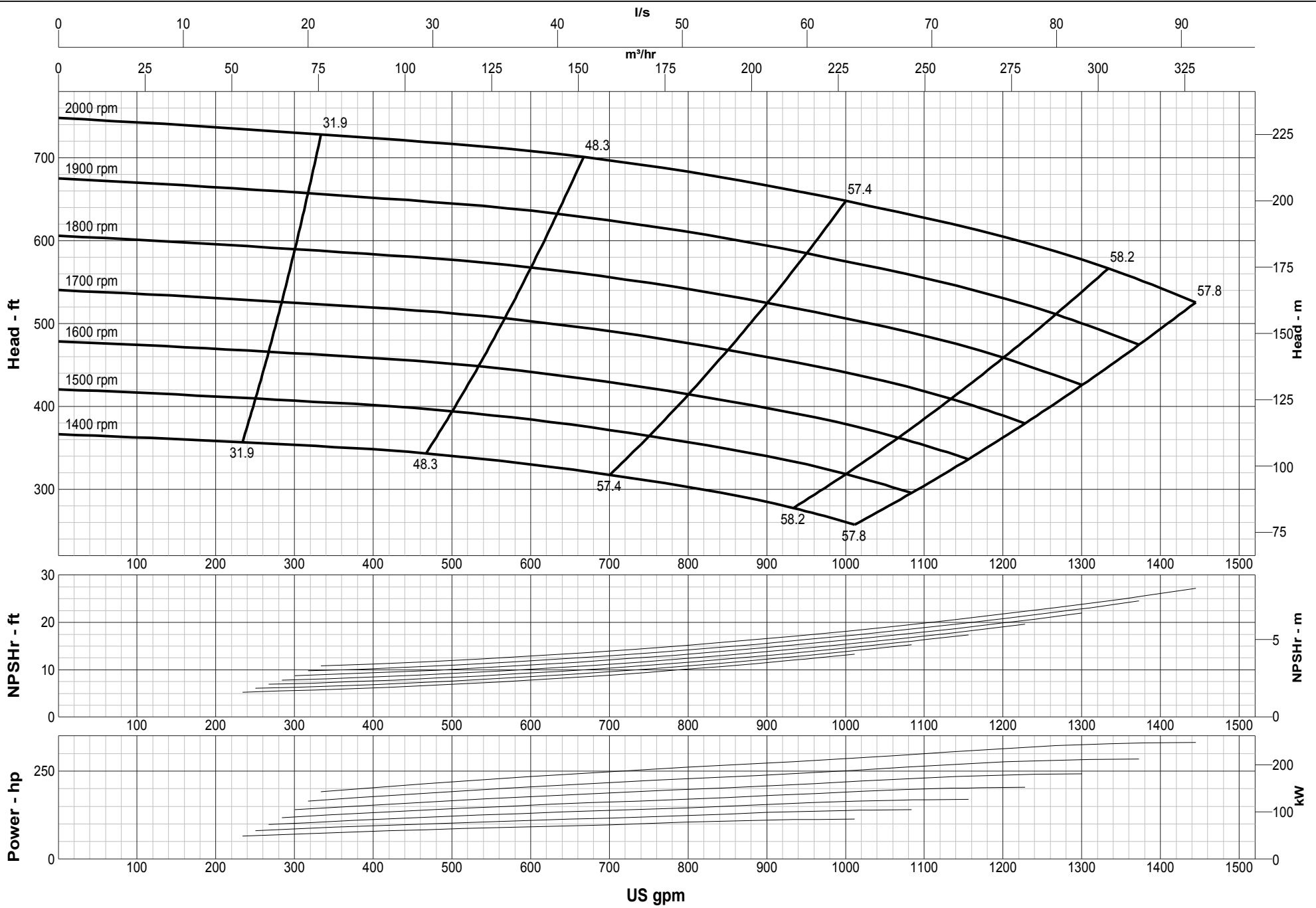

SPECIFICATIONS

Model size : 6THAP
 Speed : 1400 - 2000 rpm
 Dia : 22 in



1 819 797-3300
 TECHNOSUB.NET
 info@technosub.net