



 **TSURUMI PUMP**™
BUILT FOR WORK®
THREE PHASE DEWATERING PUMPS



Rugged Tsurumi pumps are loaded top to bottom with features to withstand your toughest dewatering applications.

- 1 Motor Protector:**
Protects against overheating and run-dry.
- 2 Anti-Wicking Block:**
Prevents water incursion due to capillary wicking should the power cable be damaged or the end submerged.
- 3 Double Inside Mechanical Seal with Silicon Carbide Faces:**
Provides the longest operational life of any available seal.
- 4 Oil Lifter:**
Lubrication of the seal faces down to 1/3 of normal oil level and greatly extends the seal life - uses no additional power.
- 5 Ball Bearings:**
Permanently lubricated, double-shielded, single row deep groove, high temperature C3 Ball bearings, Rated B-10 = 60,000 Hours.
- 6 Lip Seal Protector:**
Protects mechanical seal from abrasive particles.
- 7 High Chrome Iron / Ductile Iron Impeller:**
Resists wear by abrasive particles.
- 8 Field Adjustable / Replaceable Suction Cover:**
Resists wear by abrasive particles, and is easily adjusted to maintain pump performance.

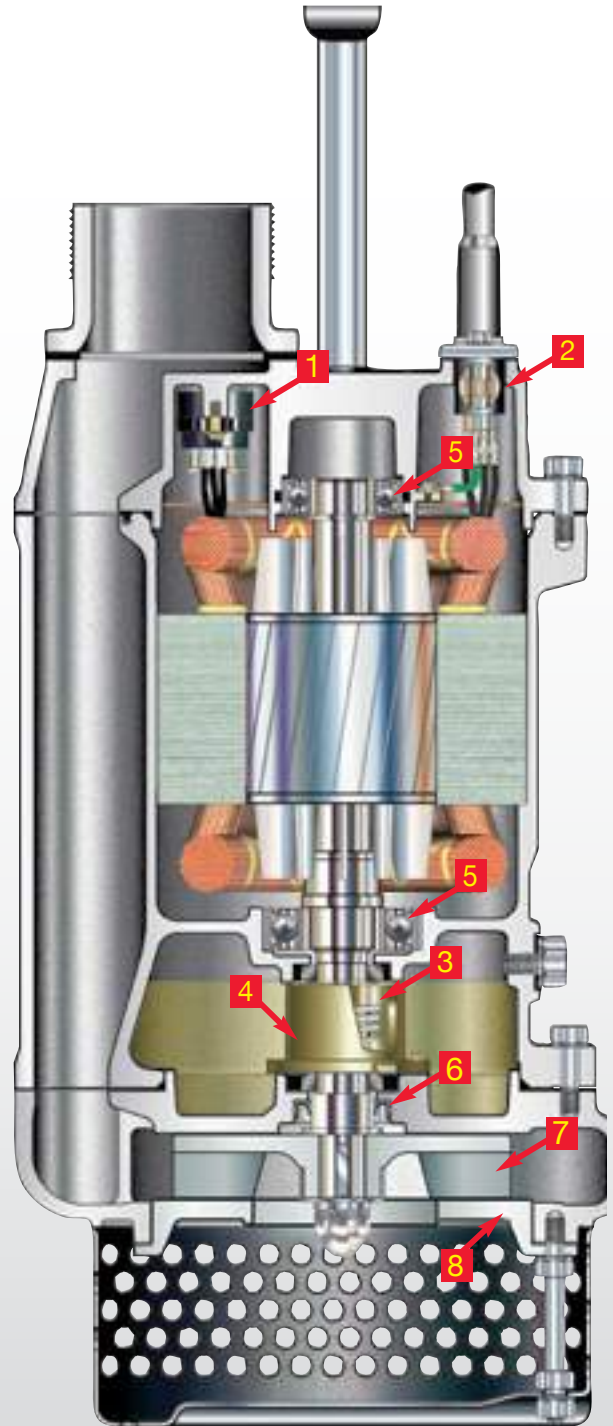

The cutaway view above is a KTZ series pump. This pump illustrates the common design features used in Tsurumi dewatering pumps. Other series may differ in shape and structure.

Three Phase Dewatering Pump Lineup

KTZ(E) Series



High head and high volume dewatering. Semi-open High Chrome Impeller.

Easy conversion between high head and high volume models in each motor size.

KTZE pumps with built-in electrode for automatic operation without a control panel.

Discharge Sizes:
2, 3, 4 and 6 inch
HP: 2, 3, 5, 7.5, 10, & 15

LH Series



Medium to high volume at high heads.

Closed High Chrome Impeller.

Easy conversion between high head and high volume models in each motor size.

Discharge Sizes:
4, 6, and 8 inch
HP: 4, 20, 30, 35, 40, 50, 60, 75, 100, 120, & 150

LHW Series



Extra high head pumping.

Dual staged, Closed High Chrome Impeller.

Pressure relief ports protect mechanical seal from excessive pressure and water hammer.

Discharge Sizes:
2, 3, and 4 inch
HP: 4, 7.5, 15, 30, 40 & 150

KTV(E) Series



Portable job-site dewatering.

Semi-vortex Urethane Rubber or Ductile Iron Impeller.

KTVE pumps with built-in electrode for automatic operation without a control panel.

Discharge Sizes:
2 and 3 inch
HP: 1, 2, 3, 5, & 7.5

KRS Series



High volume dewatering.

Semi-open Ductile Iron and High Chrome Impeller.

1800RPM and 1200 RPM motors reduce impeller wear.

Discharge Sizes
3, 4, 6, 8, 10, 12, and 14 inch
HP: 3, 5, 7.5, 10, 15, 20, 25, 30, 40, & 50

GSZ Series



High volume dewatering pumping.

Closed High Chrome and Stainless Steel Impeller.

1800 RPM and 1200 RPM motors reduce impeller wear.

Discharge Size:
6, 8, and 10 inch
HP: 30, 50, 60, 75, 100 & 200

Agitator Pumps



Heavy duty slurry pumping.

Abrasive resistant.

Single phase and three phase solutions.

Discharge Size:
2 - 10 inch
HP: 1/2 - 100

SFQ Series



Corrosive liquid dewatering.

Semi-open Stainless Steel Impeller.

All parts in contact with the liquid are 316 Stainless Steel.

All elastomers are Viton.

Discharge Size:
2, 3 and 4 inch
HP: 1, 2, 5, 7.5, 10 & 15

SQ Series



Portable corrosive liquid dewatering.

Semi-open Stainless Steel Impeller.

All parts in contact with the liquid are 304 Stainless Steel.

Discharge Size:
2 inch
HP: 1/2 & 1

LB / LBT Series



For well dewatering:
Fits n 8" casing.

Semi-Vortex Impeller.

Allows for jobsite dewatering utilizing smaller generators and smaller well casings.

Discharge Size:
2 and 3 inch
HP: 1/2, 1 & 2

SFQ • SQ | Corrosion resistant stainless steel pumps



80SFQ211



50SQ2.4S

Material

Model	SFQ	SQ
Impeller:	316 Stainless Steel	304 Stainless Steel
Casing:	316 Stainless Steel	304 Stainless Steel
Mechanical Seal:	Silicon Carbide	Silicon Carbide
Motor Frame:	316 Stainless Steel	304 Stainless Steel
Shaft:	316 Stainless Steel	304 Stainless Steel
Fasteners:	316 Stainless Steel	304 Stainless Steel
Cable:	PVC Sheath Chloroprene Sheath	PVC Sheath



Group Performance: SFQ

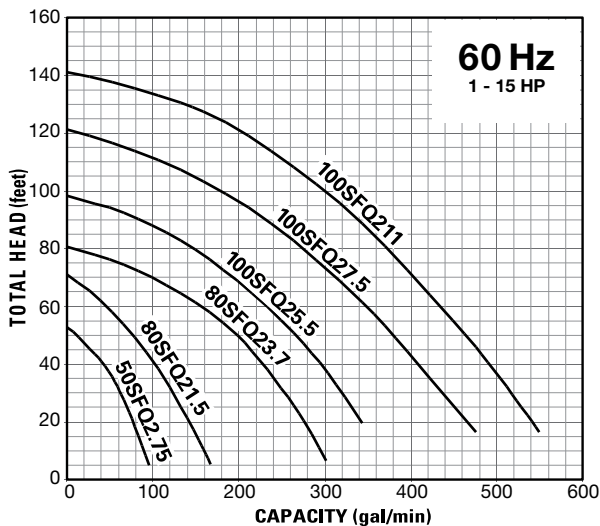

Group Performance: SQ

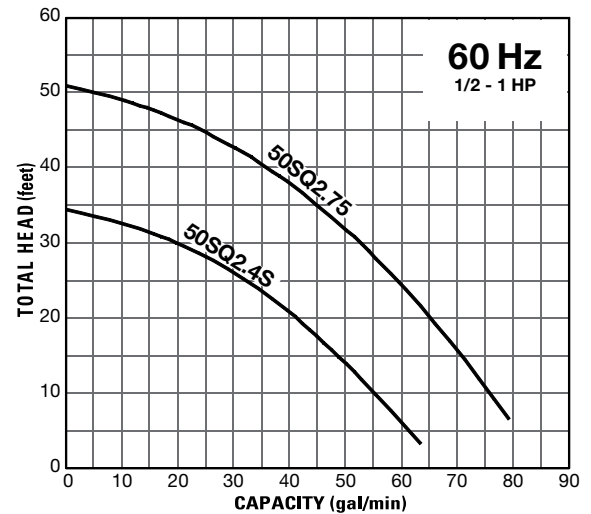

Features

SFQ Series

- All wetted components are 316 Stainless Steel
- Viton elastomers
- Dual inside mechanical seals with Silicon Carbide faces, operate in an oil filled chamber
- Built in motor protector
- Semi-open, SCS14 stainless steel impeller
- Seal pressure relief system features (7.5 - 15HP)
- Optional 316 SS Guide rail system is available for models from 7.5 - 15hp.

SQ Series

- All components including motor frame are made of SS 304 Stainless Steel.
- Non-toxic white mineral oil is used as the lubricant.
- The flow-through design and heat resistant Silicon Carbide Mechanical Seals
- Built in motor protector
- Semi-vortex, stainless steel impeller

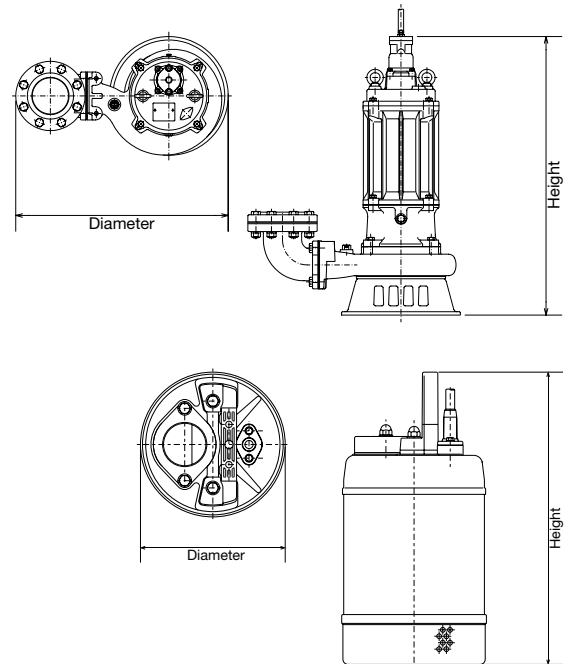
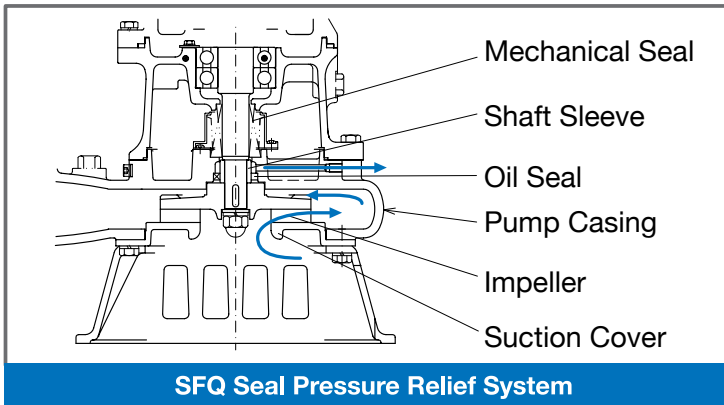

MODEL	MOTOR SPECIFICATIONS								RPM	Discharge Size (inch)	DIMENSION		Max. Solids Dia. (inch)	Continuous Running Water Level (in.)	Pump Weight (lbs.)
	Motor Output (HP)	Phase	Rated Current (A)								Diameter (in.)	Height (in.)			
			Single phase		Three phase										
115V	230V	208V	230V	460V	575V										
50SFQ2.75	1	Three	—	—	3.5	3.1	1.6	1.4	3430	2	9 15/16	15 11/16	0.236	14 1/8	49
80SFQ21.5	2	Three	—	—	6.9	6.7	3.4	2.7	3450	3	12 15/16	19 1/16	0.236	16 3/8	79
80SFQ23.7	5	Three	—	—	13.8	12.8	6.4	5	3410	3	14 1/8	21 5/16	0.591	19 1/2	115
100SFQ25.5	7.5	Three	—	—	19.3	18.2	9.4	7.5	3545	4	25 3/8	33 1/4	0.787	27 1/8	278
100SFQ27.5	10	Three	—	—	26.0	24.4	12.2	9.5	3545	4	25 3/8	33 1/4	0.787	27 1/8	276
100SFQ211	15	Three	—	—	37.0	35.2	17.6	13.9	3525	4	25 3/8	35 1/8	0.906	28	320

MODEL	MOTOR SPECIFICATIONS								RPM	Discharge Size (inch)	DIMENSION		Max. Solids Dia. (inch)	Continuous Running Water Level (in.)	Pump Weight (lbs.)
	Motor Output (HP)	Phase	Rated Current (A)								Diameter (in.)	Height (in.)			
			Single phase		Three phase										
115V	230V	208V	230V	460V	575V										
50SQ2.4S	1/2	Single	6.5	3.4	—	—	—	—	3376	2	7 1/16	14 5/16	0.236	2 3/8	28
50SQ2.75	1	Three	—	—	3.5	3.4	1.6	1.3	3349	2	7 1/16	15 1/8	0.236	2 3/8	31

TSURUMI PUMP™ ACCESSORIES

CONTROL PANELS - Automatic / Manual, VFD & Soft Start Control Panels

■ Automatic Control Panels

- UL Listed Nema 4X Fiberglass Enclosure
- HOA Selector Switch
- IEC Rated Magnetic Contactor
- Field Adjustable Overload Protection
- Includes (2) 50" Mechanical Floats



■ Manual Control Panels

- UL Listed
- Hand/Off Lockable Selector Switch
- IEC Rated Magnetic Contactor
- Field Adjustable Overload Protection
- Nema 4X Fiberglass Enclosure



■ VFD and Soft Start Control Panels

- Constant Pressure
- Constant Level
- Pace FLOW
- UL Listed
- Field Adjustable Overload Protection

Available Options Include:

- Line Reactor
- Load Reactor
- Seal Leak Protection
- Lightning Protection
- Ground-Ground Check Protection
- Elapsed Time meter
- Mechanical Floats
- Liquid Level Probes
- SCADA monitoring



TSURUMI PUMP™

BUILT FOR WORK®

TSURUMI (AMERICA), INC.

Headquarters: 1625 Fullerton Ct, Glendale Heights, IL 60139

Utah Office: 6216 West 9790 South, West Jordan, UT 84081

Tel: 1-888-878-7864 (Toll-Free) • 1-630-793-0127

Fax: 1-630-793-0146 • www.tsurumipump.com



Your Dealer

TSURUMI Canada

149 J.A. Bombardier, Suite 10
Boucherville QC J4B 8P1

+14504496484

info@tsurumicanada.com
tsurumicanada.com



Find us @tsurumiamerica