



 **TSURUMI PUMP**™
BUILT FOR WORK®
THREE PHASE DEWATERING PUMPS



Rugged Tsurumi pumps are loaded top to bottom with features to withstand your toughest dewatering applications.

- 1 Motor Protector:**
Protects against overheating and run-dry.
- 2 Anti-Wicking Block:**
Prevents water incursion due to capillary wicking should the power cable be damaged or the end submerged.
- 3 Double Inside Mechanical Seal with Silicon Carbide Faces:**
Provides the longest operational life of any available seal.
- 4 Oil Lifter:**
Lubrication of the seal faces down to 1/3 of normal oil level and greatly extends the seal life - uses no additional power.
- 5 Ball Bearings:**
Permanently lubricated, double-shielded, single row deep groove, high temperature C3 Ball bearings, Rated B-10 = 60,000 Hours.
- 6 Lip Seal Protector:**
Protects mechanical seal from abrasive particles.
- 7 High Chrome Iron / Ductile Iron Impeller:**
Resists wear by abrasive particles.
- 8 Field Adjustable / Replaceable Suction Cover:**
Resists wear by abrasive particles, and is easily adjusted to maintain pump performance.

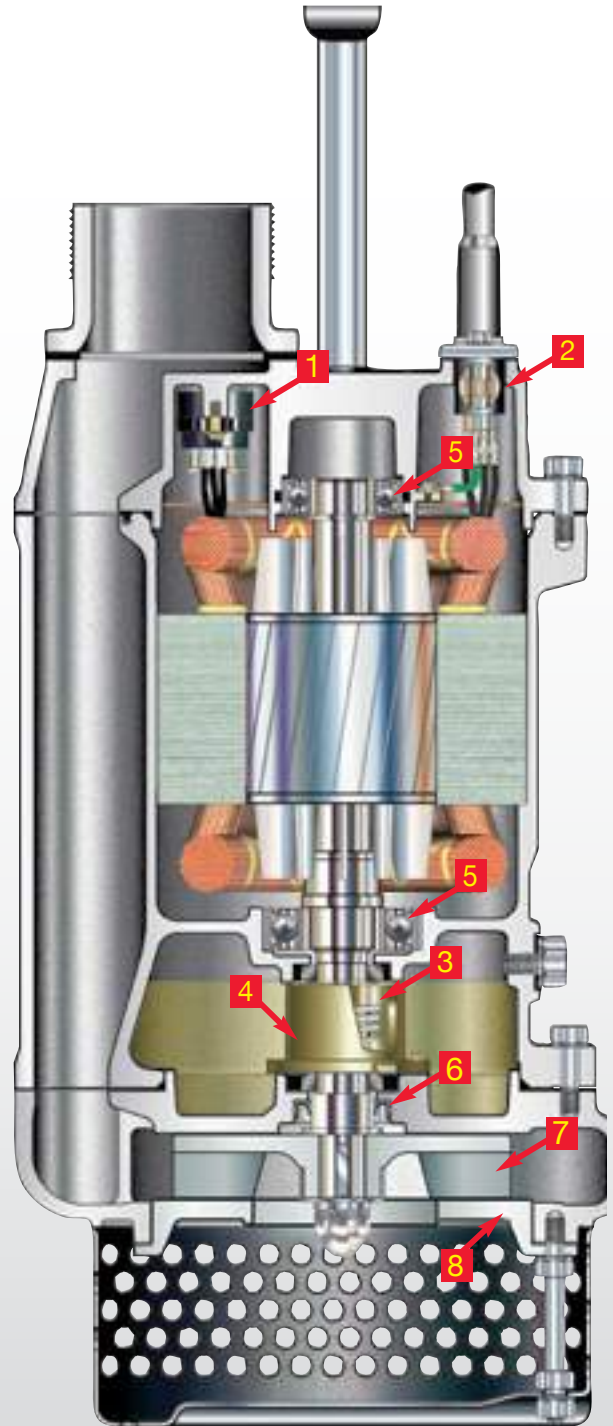

The cutaway view above is a KTZ series pump. This pump illustrates the common design features used in Tsurumi dewatering pumps. Other series may differ in shape and structure.



Specifications

Type of Fluid: Sludge, muddy water, sandy mud

Applications

- Grit chambers, mine processing plants where light to medium abrasive solids need to stay suspended for pumping in wastewater
- Heavy abrasive construction site dewatering
- Aggregate wash down
- Ragoon / sludge pond cleanout



Group Performance
HS, HSD, NK, KTD and KTV

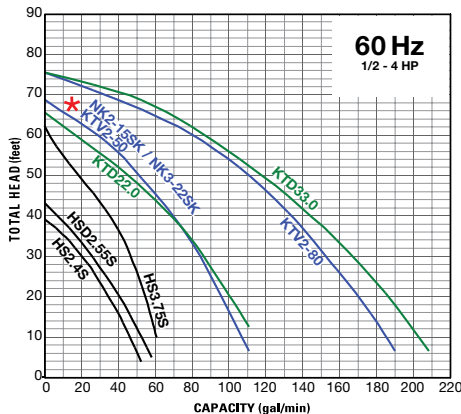

	Standard	High Torque
Single Phase	NK2-15SK 2HP (1.5kW)	NK3-22SK 3HP (2.2kW)
Three Phase	—	KTV2-50 2.7HP (2.0kW)

High Torque models further suitable for heavy duty application.

Group Performance
KRS and GPN

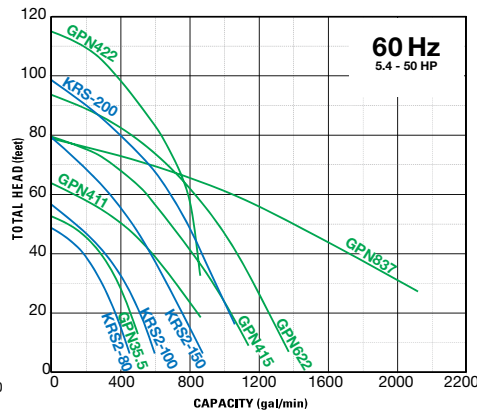

Group Performance
GSD

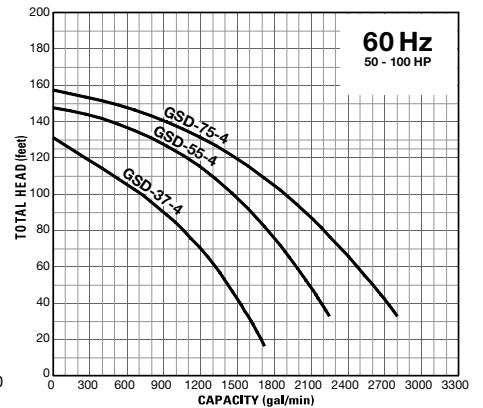



Tsurumi Agitator Pumps are designed for sludge slurry pumping with hard iron adjustable wear parts. Up to 10" discharge size / 100HP with 4 pole / 6 pole motors for slower impeller tip speed which prolongs pump life.

Additional options which may help extend the life of the wear parts in tough applications are available. (Consult factory for recommendations)

Additional optional special coating available.

KRS Series convert from regular hydraulic configuration to agitator versions with stock parts for more flexibility.

GPN Series / GSD Series only: Bottom side discharge

■ Agitator

Tsurumi's slurry pumps have an agitator made of abrasion resistant material. It is mounted on the shaft and rotates to create a downward current. This agitator assists the pump in suspending and transferring solids such as bentonite slurry, slime, mud, and water with high sand content.



MODEL	MOTOR SPECIFICATIONS								Discharge Size (inch)	DIMENSION		Max. Solids Dia. (inch)	Continuous Running Water Level (in.)	Pump Weight (lbs.)	
	Motor Output (HP)	Phase	Rated Current (A)							RPM	Diameter (in.)				Height (in.)
			Single phase		Three phase										
			115V	230V	208V	230V	460V	575V							
HS2.4S	1/2	Single	5.2	2.7	—	—	—	—	3320	2	10 1/16	12 15/16	0.276	3 1/2	25
HS3.75S	1	Single	9.7	4.9	—	—	—	—	3411	3	12 7/16	15 5/16	0.276	3 1/2	43
HSD2.55S	3/4	Single	7.3	3.7	—	—	—	—	3390	2	10 3/8	15 3/8	0.394	4 1/8	34
NK2-15SK	2	Single	23.0*	11.5*	—	—	—	—	3440	3	9 13/16	26	0.334	4 3/4	71
NK3-22SK	3	Single	—	13*	—	—	—	—	3465	3	9 13/16	26	0.334	4 3/4	71
KTV2-50	2.7	Three	—	—	7	6.4	3.2	2.6	3440	2	9 13/16	17 7/8	0.334	4 3/4	55
KTV2-80	4	Three	—	—	11.6	10.6	5.3	4.2	3450	3	11 5/8	21 5/8	0.334	5 1/8	84
KTD22.0	2.7	Three	—	—	8.7*	8.2	4.1	3.3	3410	2	9 1/4	23 3/16	0.394	5 1/2	86
KTD33.0	4	Three	—	—	12*	11.4	5.9	4.5	3410	3	11 11/16	25 3/4	0.394	6 1/4	145
KRS2-80	5.4	Three	—	—	18*	16.5	8.5	6.6	1720	3	13 3/4	30 11/16	1.18	9 7/8	231
KRS2-100	8	Three	—	—	25*	23	11.5	9.2	1730	4	16 3/8	30 7/8	1.18	10 5/8	315
KRS2-150	12	Three	—	—	36*	33	16.5	13.2	1735	6	16 3/8	33	1.18	10 5/8	357
KRS-200	24	Three	—	—	—	—	30	24	1750	8	22 11/16	44 7/8	1.18	11 1/4	840
GPN35.5	7.5	Three	—	—	21.4	20*	9.8	7.6	1720	3	3/16	31 5/16	1.18	11 3/8	319
GPN411	15	Three	—	—	42	39*	19.5	14.5	1735	4	24 5/16	34 5/8	1.18	12 3/8	478
GPN415	22	Three	—	—	55	52*	24	20	1735	4	24 5/16	34 5/8	1.18	12 3/8	485
GPN422	30	Three	—	—	—	—	36.5	29.5	1750	4	28 9/16	43 3/8	1.18	11 3/4	910
GPN622	30	Three	—	—	—	—	36.5	29.5	1750	6	28 9/16	43 3/8	1.18	11 3/4	910
GPN837	50	Three	—	—	—	—	64	52	1160	8	39 15/16	63 1/4	1.81	22	1760
GSD-37-4	50	Three	—	—	—	—	63	49.5	1740	8	36	62 5/16	0.984	18 7/8	1290
GSD-55-4	75	Three	—	—	—	—	97	76	1775	10	41 5/16	75 7/8	0.984	20 1/8	2440
GSD-75-4	100	Three	—	—	—	—	128	101	1775	10	41 5/16	75 7/8	0.984	20 1/8	2690

* Dual Voltage

TSURUMI PUMP™ ACCESSORIES

CONTROL PANELS - Automatic / Manual, VFD & Soft Start Control Panels

■ Automatic Control Panels

- UL Listed Nema 4X Fiberglass Enclosure
- HOA Selector Switch
- IEC Rated Magnetic Contactor
- Field Adjustable Overload Protection
- Includes (2) 50" Mechanical Floats



■ Manual Control Panels

- UL Listed
- Hand/Off Lockable Selector Switch
- IEC Rated Magnetic Contactor
- Field Adjustable Overload Protection
- Nema 4X Fiberglass Enclosure



■ VFD and Soft Start Control Panels

- Constant Pressure
- Constant Level
- Pace FLOW
- UL Listed
- Field Adjustable Overload Protection

Available Options Include:

- Line Reactor
- Load Reactor
- Seal Leak Protection
- Lightning Protection
- Ground-Ground Check Protection
- Elapsed Time meter
- Mechanical Floats
- Liquid Level Probes
- SCADA monitoring



TSURUMI PUMP™

BUILT FOR WORK®

TSURUMI (AMERICA), INC.

Headquarters: 1625 Fullerton Ct, Glendale Heights, IL 60139

Utah Office: 6216 West 9790 South, West Jordan, UT 84081

Tel: 1-888-878-7864 (Toll-Free) • 1-630-793-0127

Fax: 1-630-793-0146 • www.tsurumipump.com



Your Dealer

TSURUMI Canada

149 J.A. Bombardier, Suite 10
Boucherville QC J4B 8P1

+14504496484

info@tsurumicanada.com
tsurumicanada.com



Find us @tsurumiamerica