



 **TSURUMI PUMP**™
BUILT FOR WORK®
THREE PHASE DEWATERING PUMPS



Rugged Tsurumi pumps are loaded top to bottom with features to withstand your toughest dewatering applications.

- 1 Motor Protector:**
Protects against overheating and run-dry.
- 2 Anti-Wicking Block:**
Prevents water incursion due to capillary wicking should the power cable be damaged or the end submerged.
- 3 Double Inside Mechanical Seal with Silicon Carbide Faces:**
Provides the longest operational life of any available seal.
- 4 Oil Lifter:**
Lubrication of the seal faces down to 1/3 of normal oil level and greatly extends the seal life - uses no additional power.
- 5 Ball Bearings:**
Permanently lubricated, double-shielded, single row deep groove, high temperature C3 Ball bearings, Rated B-10 = 60,000 Hours.
- 6 Lip Seal Protector:**
Protects mechanical seal from abrasive particles.
- 7 High Chrome Iron / Ductile Iron Impeller:**
Resists wear by abrasive particles.
- 8 Field Adjustable / Replaceable Suction Cover:**
Resists wear by abrasive particles, and is easily adjusted to maintain pump performance.

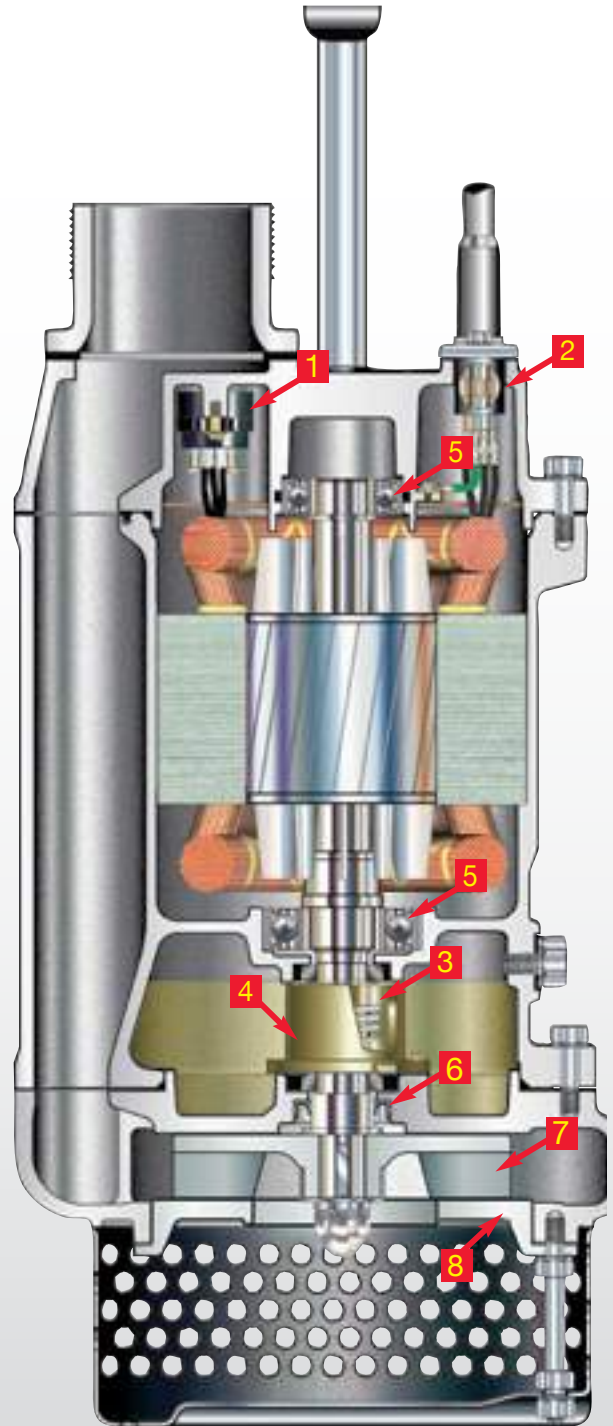

The cutaway view above is a KTZ series pump. This pump illustrates the common design features used in Tsurumi dewatering pumps. Other series may differ in shape and structure.

Three Phase Dewatering Pump Lineup

KTZ(E) Series



High head and high volume dewatering. Semi-open High Chrome Impeller.

Easy conversion between high head and high volume models in each motor size.

KTZE pumps with built-in electrode for automatic operation without a control panel.

Discharge Sizes:
2, 3, 4 and 6 inch
HP: 2, 3, 5, 7.5, 10, & 15

LH Series



Medium to high volume at high heads.

Closed High Chrome Impeller.

Easy conversion between high head and high volume models in each motor size.

Discharge Sizes:
4, 6, and 8 inch
HP: 4, 20, 30, 35, 40, 50, 60, 75, 100, 120, & 150

LHW Series



Extra high head pumping.

Dual staged, Closed High Chrome Impeller.

Pressure relief ports protect mechanical seal from excessive pressure and water hammer.

Discharge Sizes:
2, 3, and 4 inch
HP: 4, 7.5, 15, 30, 40 & 150

KTV(E) Series



Portable job-site dewatering.

Semi-vortex Urethane Rubber or Ductile Iron Impeller.

KTVE pumps with built-in electrode for automatic operation without a control panel.

Discharge Sizes:
2 and 3 inch
HP: 1, 2, 3, 5, & 7.5

KRS Series



High volume dewatering.

Semi-open Ductile Iron and High Chrome Impeller.

1800RPM and 1200 RPM motors reduce impeller wear.

Discharge Sizes
3, 4, 6, 8, 10, 12, and 14 inch
HP: 3, 5, 7.5, 10, 15, 20, 25, 30, 40, & 50

GSZ Series



High volume dewatering pumping.

Closed High Chrome and Stainless Steel Impeller.

1800 RPM and 1200 RPM motors reduce impeller wear.

Discharge Size:
6, 8, and 10 inch
HP: 30, 50, 60, 75, 100 & 200

Agitator Pumps



Heavy duty slurry pumping.

Abrasive resistant.

Single phase and three phase solutions.

Discharge Size:
2 - 10 inch
HP: 1/2 - 100

SFQ Series



Corrosive liquid dewatering.

Semi-open Stainless Steel Impeller.

All parts in contact with the liquid are 316 Stainless Steel.

All elastomers are Viton.

Discharge Size:
2, 3 and 4 inch
HP: 1, 2, 5, 7.5, 10 & 15

SQ Series



Portable corrosive liquid dewatering.

Semi-open Stainless Steel Impeller.

All parts in contact with the liquid are 304 Stainless Steel.

Discharge Size:
2 inch
HP: 1/2 & 1

LB / LBT Series



For well dewatering: Fits n 8" casing.

Semi-Vortex Impeller.

Allows for jobsite dewatering utilizing smaller generators and smaller well casings.

Discharge Size:
2 and 3 inch
HP: 1/2, 1 & 2

LH / LHW SERIES | Extreme high pressure pumping at high volumes



Material

- Impeller: High Chrome Iron
- Casing: Ductile Cast Iron
- Mechanical Seal: Silicon Carbide
- Motor Frame: Cast Iron
- Shaft: 420 Stainless Steel
- Fasteners: 304 Stainless Steel
- Cable: Chloroprene Sheath

Features

- High Pressure Capability
- High Pressure Rated Mechanical Seals
- Seal Pressure Relief Ports
- Rugged Iron Construction
- Anti-Wicking Cable Entrance
- Dual Silicon Carbide Mechanical Seals
- Oil Lifter
- Internal Thermal Motor Protection

Group Performance Curves: LH / LHW Series Pumps

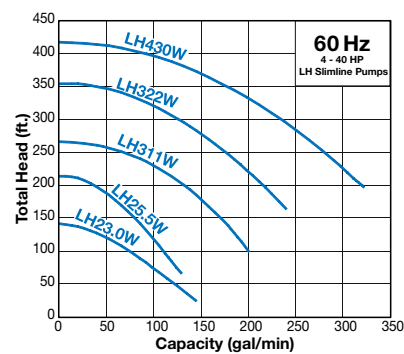
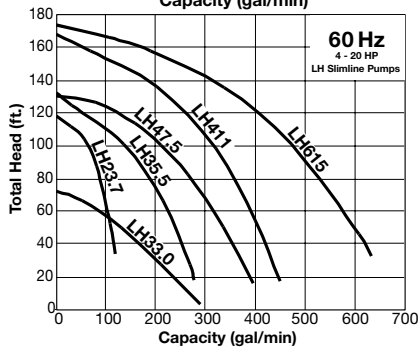
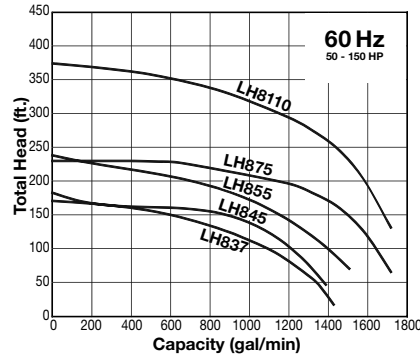
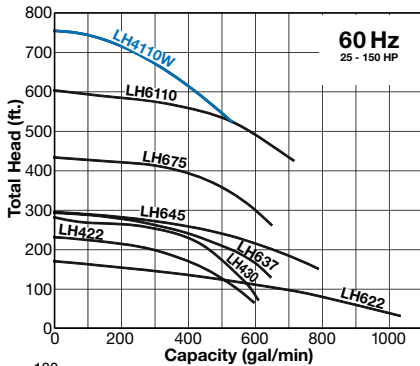

LH Series handles medium to high flows at higher heads, yet its top discharge flow-through design welcomes low water level operation for extended periods. Complete with a high chromium semi-open impeller and adjustable wear rings, our LH pumps provide you with increased wear resistance whether your application is construction site drainage, or commercial/ industrial mine dewatering, or effluent transfer.

LH-W series achieves extremely high head pressure. Our dual enclosed impellers are just one of many features found engineered into these durable pumps which can help you solve all your long distance water transfer needs.

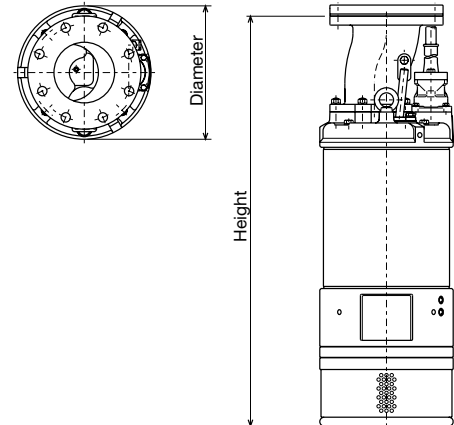

: Slimline Pumps - Pump diameter less than 15"

MODEL	MOTOR SPECIFICATIONS						Discharge Size (inch)	DIMENSION		Max. Solids Dia. (inch)	Continuous Running Water Level (in.)	Pump Weight (lbs.)
	Output (HP)	Rated Current (A)				RPM		Diameter	Height			
		208V	230V	460V	575V							
LH23.0W	4	12.3	12	6.0	4.7	3430	2	7 5/16	24 13/16	0.236	7 7/8	101
LH25.5W	7.5	22	19.2	9.6	7.7	3385	2	9 5/8	29 1/2	0.236	6 3/4	176
LH311W	15	42	37	18.5	14.5	3465	3	10 5/8	40 5/16	0.334	7 7/8	287
LH322W	30	—	—	35.5	28	3490	3	13	48 5/8	0.334	11 3/4	670
LH430W	40	—	—	48	38.5	3475	4	14 3/8	54 1/8	0.334	11 3/4	714
LH4110W	150	—	—	181	145	3570	4	24 1/2	71 7/8	0.315	15 3/4	2800

MODEL	MOTOR SPECIFICATIONS						Discharge Size (inch)	DIMENSION		Max. Solids Dia. (inch)	Continuous Running Water Level (in.)	Pump Weight (lbs.)
	Output (HP)	Rated Current (A)				RPM		Diameter	Height			
		208V	230V	460V	575V							
LH33.0	4	12.3	12	6.0	4.7	3430	3	7 5/16	25 3/8	0.236	5 7/8	93
LH23.7	5	14.6	14.6	7.3	—	3420	3	10	31 1/8	0.334	5 7/8	200
LH35.5	7.5	20.5	19.4	10	—	3430	2	10	31 1/8	0.334	5 7/8	220
LH47.5	10	28	26.5	13.5	—	3490	3	11 13/16	35 1/2	0.334	6 1/4	325
LH411	15	41	38.5	19.5	—	3495	4	11 13/16	35 1/2	0.334	6 1/4	345
LH615	20	53.8	48	24	19	3465	6	13	39 15/16	0.334	7 1/4	470
LH422	30	—	—	36	28.5	3490	4	16 9/16	53 1/4	0.236	9 7/8	770
LH622	30	—	—	36	28.5	3490	6	16 9/16	56	0.472	10 5/8	790
LH430	40	—	—	51	38.5	3475	4	16 9/16	53 1/4	0.236	9 7/8	780
LH637	50	—	—	58	46	3525	6	20 7/8	57	0.236	7 1/8	1090
LH837	50	—	—	58	46	3525	8	20 7/8	58 9/16	0.787	7 1/8	1090
LH645	60	—	—	67	53	3530	6	20 7/8	57	0.236	7 1/8	1120
LH845	60	—	—	67	53	3530	8	20 7/8	58 9/16	0.787	7 1/8	1120
LH855	75	—	—	87	70	3530	8	21 5/8	67 9/16	0.787	7 7/8	1810
LH675	100	—	—	113	91	3530	6	21 5/8	66	0.315	7 7/8	1910
LH875	100	—	—	113	91	3530	8	21 5/8	67 9/16	0.787	7 7/8	1910
LH6110	150	—	—	181	145	3570	6	24 1/2	74 5/16	0.394	7 7/8	2670
LH8110	150	—	—	181	145	3570	8	24 1/2	74 5/16	0.787	7 7/8	2670

FOR SPECIAL PUMPING | Submersible Seawater-Resistant Dewatering Pumps

Seawater Resistant Kit

Tsurumi's standard pumps can be combined with a seawater-resistant kit (optional) that adds a galvanic anode and seawater-resistant special cast iron impeller, and enables about two years of service. (The service period depends on operating conditions.)

- ✓ Galvanic Anodes (with Fittings, Seal Putty)
- ✓ Seawater-Resistant Special Cast Iron Impeller
- ✓ 304 Stainless Steel Eye Bolts*
* Applicable only with models having steel eye bolts



KTZ33.7

LH311W

KRS815

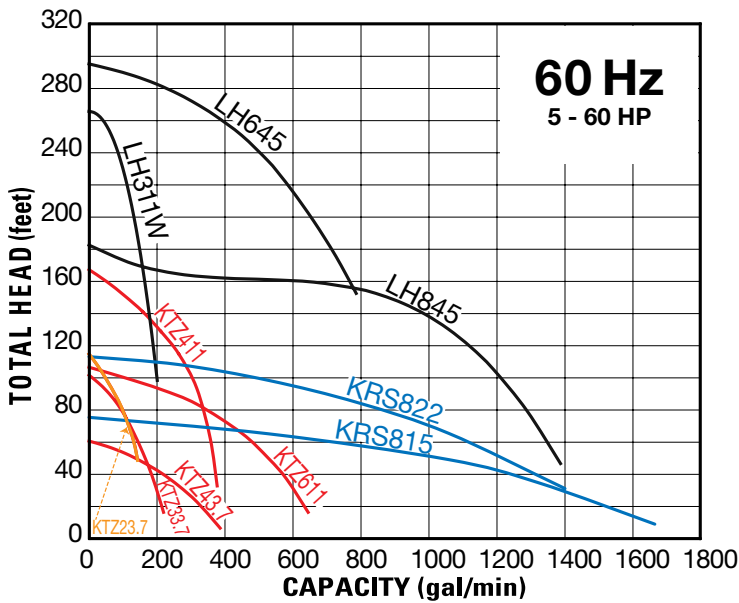

The **galvanic anode** is an electrolytic protective measure used with metals of differing corrosive potentials. Metals of a potential lower (aluminium and zinc) than the pump body (cast iron and steel) are brought into contact with the body via the galvanic anodes and allowed to corrode in order to protect the body. However, the full effect cannot be obtained unless the anodes are installed in the proper positions.

Tsurumi mainly utilizes aluminium because of its superior anticorrosive performance per unit weight, while utilizing zinc for only the strainer stand that is liable to be worn by water current. Since the galvanic anodes are worn by corrosion, they need to be replaced every two years. They can be replaced easily and used immediately after replacement.



Aluminium

Zinc

Corrosion Test (in seawater, 1 year)

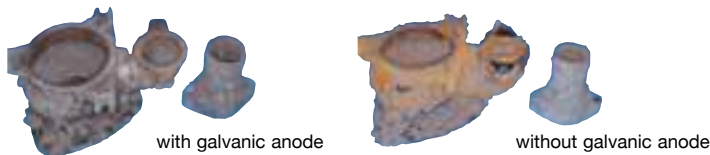

with galvanic anode

without galvanic anode

MODEL	MOTOR SPECIFICATIONS					Discharge Size (inch)	DIMENSION		Max. Solids Dia. (inch)	Continuous Running Water Level (in.)	Pump Weight (lbs.)	
	Output (HP)	Rated Current (A)					RPM	Diameter				Height
		208V	230V	460V	575V							
KTZ23.7	5	15	13.6	6.8	5.3	3410	2	11 1/8	26 1/4	0.334	5 7/8	137
KTZ43.7	5	15	13.6	6.8	5.3	3410	4	11 1/8	27 1/16	0.334	5 7/8	137
KTZ411	15	39.8	37.4	18.6	14.9	3520	4	14 3/4	32 15/16	0.472	7 1/2	293
KTZ611	15	39.8	37.4	18.6	14.9	3520	4	14 3/4	32 15/16	0.787	7 1/2	295
LH645	60	—	—	67	53	3530	6	20 7/8	57	0.236	9 7/8	780
LH845	60	—	—	67	53	3530	8	20 7/8	58 9/16	0.787	7 1/8	1120
LH311W	15	42	37	18.5	14.5	3465	3	10 5/8	40 5/16	0.334	7 7/8	287
KRS815	20	57.9	55.7	27.9	22.2	1735	8	18 15/16	38 9/16	0.984	10 7/8	530
KRS822	30	—	—	38.5	30.8	1745	8	22 11/16	47 1/4	0.984	13 5/8	840

FOR SPECIAL PUMPING | Tandem Operation - LH • LHW



Tandem operation is an operation method that connects two pumps of the same model in series. This provides ultra high head at the same flow rate in comparison with that of a single pump. The principle of tandem operation is the same as that with multistage pumps. The LH and LHW series pumps adopt the center flange construction to align the discharge pipe with the cylindrical pump center axis.* Connecting the pumps in series with the tandem connector can provide higher pump head without affecting the advantage of the slim design. At construction sites, there are many cases where a higher pump head is required as construction work progresses. In such cases, the addition of a tandem pump may meet the required pump head, instead of using a new pump.

* Available as an option for separately purchased LH33.0 and LH23.0W.

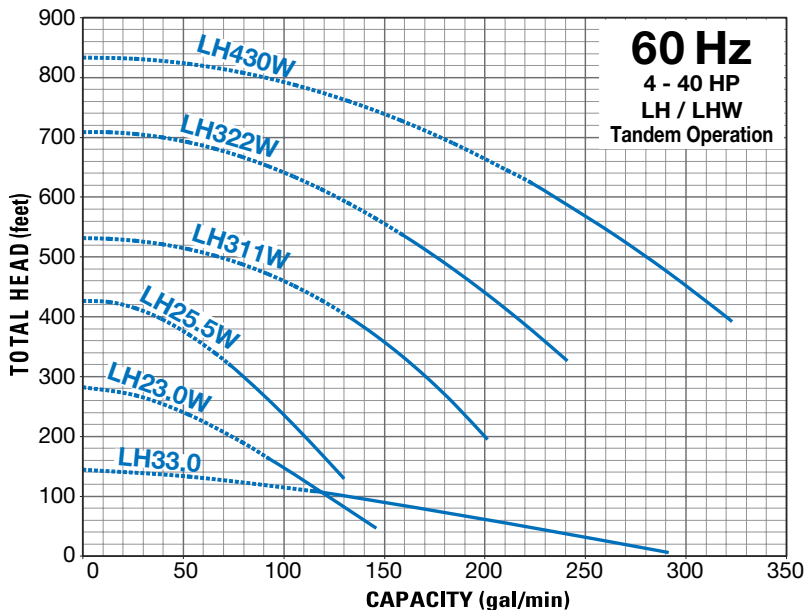

REMARKS:

The intermediate connection pipe is not required in the range indicated as a bold line on curves. If the required total head exceeds the maximum head of the pump without an intermediate connection pipe (indicated as dashed line), an intermediate connection pipe of a length corresponding to the excess amount or more is required.*

*Consult factory for design assistance

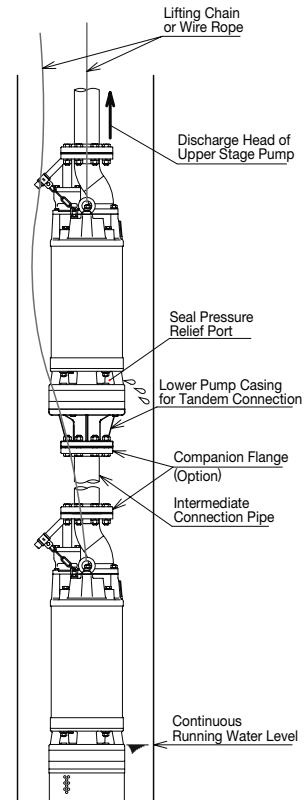

MODEL	MOTOR SPECIFICATIONS					RPM	Discharge Size (inch)	DIMENSION		Max. Solids Dia. (inch)	Continuous Running Water Level (in.)	Pump Weight (lbs.)
	Output (HP)	Rated Current (A)						Diameter	Height			
		208V	230V	460V	575V							
LH33.0	4	12.3*	12	6.0	4.7	3430	3	7 5/16	25 3/8	0.236	5 7/8	93
LH23.0W	4	12.3*	12	6.0	4.7	3430	2	7 5/16	24 13/16	0.236	7 7/8	101
LH25.5W	7.5	22	19.2	9.6	7.7	3385	2	9 5/8	29 1/2	0.236	6 3/4	176
LH311W	15	42	37	18.5	14.5	3465	3	10 5/8	40 5/16	0.334	7 7/8	287
LH322W	30	—	—	35.5	28	3490	3	13	48 5/8	0.334	11 3/4	670
LH430W	40	—	—	48	38.5	3475	4	14 3/8	54 1/8	0.334	11 3/4	714

* 208 & 230V same motor

TSURUMI PUMP™ ACCESSORIES

CONTROL PANELS - Automatic / Manual, VFD & Soft Start Control Panels

■ Automatic Control Panels

- UL Listed Nema 4X Fiberglass Enclosure
- HOA Selector Switch
- IEC Rated Magnetic Contactor
- Field Adjustable Overload Protection
- Includes (2) 50" Mechanical Floats



■ Manual Control Panels

- UL Listed
- Hand/Off Lockable Selector Switch
- IEC Rated Magnetic Contactor
- Field Adjustable Overload Protection
- Nema 4X Fiberglass Enclosure



■ VFD and Soft Start Control Panels

- Constant Pressure
- Constant Level
- Pace FLOW
- UL Listed
- Field Adjustable Overload Protection

Available Options Include:

- Line Reactor
- Load Reactor
- Seal Leak Protection
- Lightning Protection
- Ground-Ground Check Protection
- Elapsed Time meter
- Mechanical Floats
- Liquid Level Probes
- SCADA monitoring



TSURUMI PUMP™

BUILT FOR WORK®

TSURUMI (AMERICA), INC.

Headquarters: 1625 Fullerton Ct, Glendale Heights, IL 60139

Utah Office: 6216 West 9790 South, West Jordan, UT 84081

Tel: 1-888-878-7864 (Toll-Free) • 1-630-793-0127

Fax: 1-630-793-0146 • www.tsurumipump.com



Your Dealer

TSURUMI Canada

149 J.A. Bombardier, Suite 10
Boucherville QC J4B 8P1

+14504496484

info@tsurumicanada.com
tsurumicanada.com



Find us @tsurumiamerica