



TSURUMI PUMP®

BUILT FOR WORK®

SEWAGE AND

WASTEWATER PUMPS



SIMPLE DESIGN, EXTREME QUALITY | Tsurumi C Series CUTTER PUMP™

Cable Entry

Cables are designed with an anti-wicking block at motor entry where each conductor insulation is window cut and the exposed stranded wire is encapsulated in molded rubber or epoxy which eliminates moisture from wicking into the motor.



Motor

The air filled, continuous duty motors are designed to accommodate a maximum liquid temperature of 104°F. Higher temperature options may be available upon request.

Mechanical Seal

Dual mechanical seal with silicon carbide faces sits within the oil chamber. The oil prevents corrosion, abrasion or fouling of the seal's spring and seal faces due to contamination, and also provides cooling and lubrication of the seal faces, even in run-dry conditions. These are common points of failure in designs where the seal is lubricated by the pumpage as opposed to oil.



Oil Lifter

The Oil Lifter, utilizing centrifugal force, supplies lubricating oil to the upper seal faces even if oil falls below the rated volume, or pump is oriented horizontally.

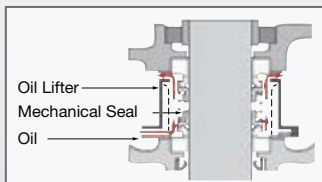

Motor Protector

A Circle Thermal Protector (CTP) integrated in the motor housing directly cuts the motor circuit if excessive heat builds up or an electrical/mechanical failure leads to overcurrent.

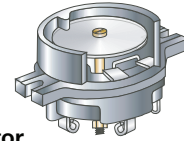

In pumps 15 HP and larger, a Miniature Thermal Protector (MTP) is embedded in each winding of the motors. Should the winding temperature rise to the actuating temperature, the bimetal strip opens to cut off power supply.



Moisture Sensor

An internal moisture sensor is standard for all pumps 30 HP and larger. An external moisture sensor is available as an option to detect intrusion of water in the oil chamber. Internal and External sensors, when wired to a control panel, alert the operator of a potential leak.



Impeller & Cutter Plate

A tungsten carbide cutter is brazed onto the impeller vane, and rotates along the serrated entry of the cutter plate. Incoming fibrous matters are cut up which prevents clogging.



GUIDE RAIL FITTING SYSTEM

The guide rail fitting system connects the pump to and from the piping easily just by lowering and hoisting the pump, allowing easy maintenance and inspection without the need to enter the sump. Pump models used in combination with the guide rail fitting system can be identified by the prefix "TOS / TO" and "TOK". Refer to standard specifications for availability and model numbers.

The **TOS / TO** is the standard guide rail fitting system made of cast-iron and is compatible with cast-iron pumps. Pumps having a discharge bore from 2 inches to 6 inches are available for the TOS, and from 8 inches to 32 inches are available for the TO.



The **TOK** guide rail connecting system is made of a high-quality corrosion resistant resin. This system is specifically designed for use with the corrosion resistant, light weight VANCS™ pumps (Page 16).



MODEL NUMBER DESIGNATION

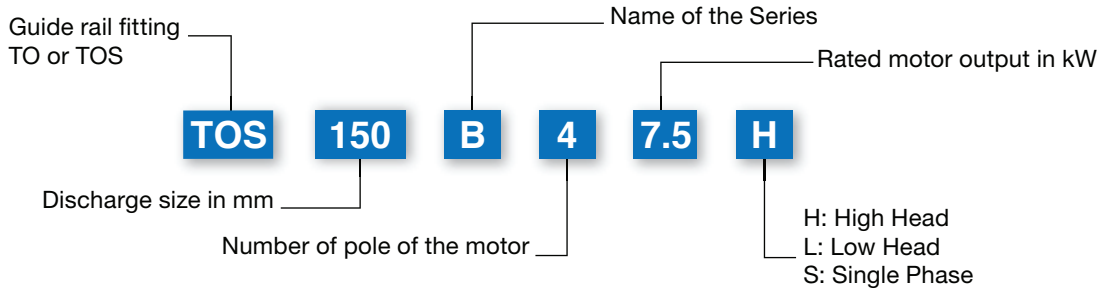

INSTALLATION

Free Standing

Simple installation in the sump saves both money and space.

Pump's with legs or a stand can sit directly on the sump floor. A discharge bend and flexible hosing allows for simple install/removal. Install the pump on a pump base if waste could clog or block its suction inlet.

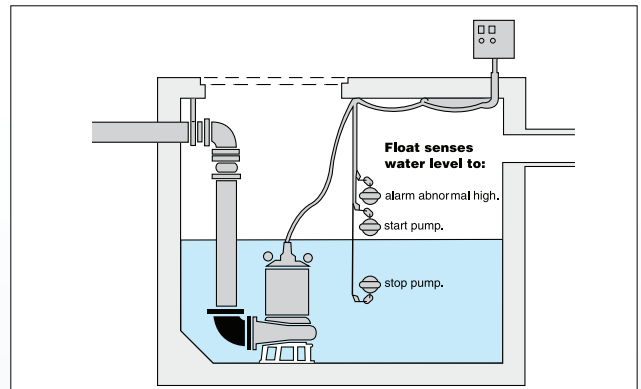

Guide-Rail Fitting

A guide rail suspends the pump with a chain for quick, easy installation or removal.

Mount the pump on the rails using a guide hook above the discharge flange. As the pump is lowered, a hook on the discharge flange locks into and positions against the discharge elbow's flange. No tools or hardware are required as the weight of the pump seals the mated flanges. To remove the pump, simply raise with the chain and the pump will lift along the guide rails.

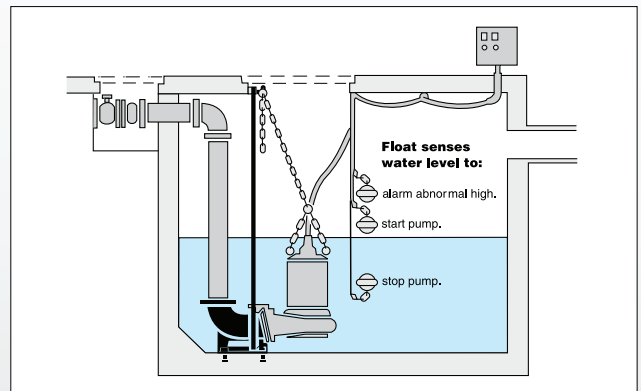

DIMENSIONAL DRAWING DESCRIPTION

Dimension: Free Standing A / B / C

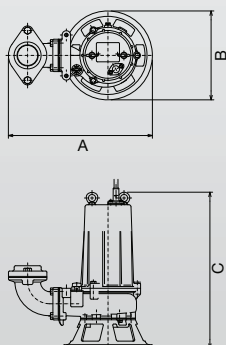

Dimension: Guide Rail Fitting (TO / TOS) D / E / F

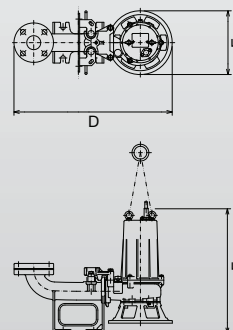

U SERIES | Semi-Vortex Cast Iron Impeller

Tsurumi's U Series pumps provide exceptional capabilities for those small to mid-range applications in which solids and stringy materials can be problematic.

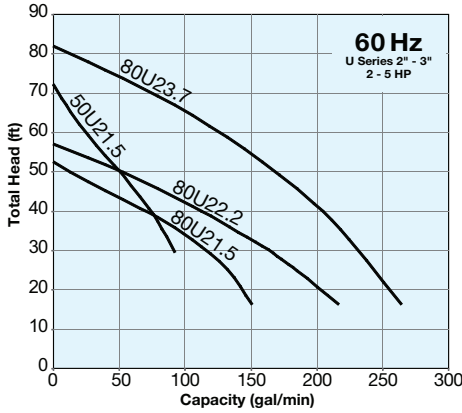

U Series pump with elbow

Dimension: Free Standing A / B / C Dimension: Guide Rail Fitting (TO / TOS) D / E / F

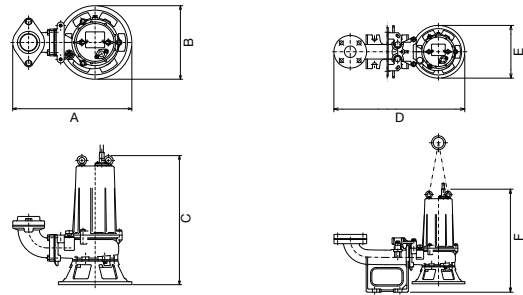

Three Phase Model	Motor Output (HP)	Rated Current (A)				*S.S. (RPM)	Discharge Size (in.)	Dimensions (in.)						Max. Solids Dia. (in.)
		208V	230V	460V	575V			Free Standing Models			TOS Guide Rail Models			
								A	B	C	D	E	F	
50U21.5	2	6.2	5.9	3.1	2.3	3600	2	11 11/16	7 15/16	18 3/8	25 7/8	7 15/16	18 13/16	1.38
80U21.5	2	6.2	5.9	3.1	2.3	3600	3	16 9/16	7 15/16	19 5/8	23 7/8	7 15/16	23 11/16	1.81
80U22.2	3	9.4	8.8	4.4	3.5	3600	3	20 1/2	9 7/16	22 1/8	24 15/16	9 7/16	25 1/2	2.20
80U23.7	5	14.4	13.6	6.8	5.3	3600	3	20 1/2	9 3/16	22 1/4	24 15/16	9 3/16	25 9/16	2.20

* Synchronous Speed

UT • UTZ SERIES | Single Phase Cast Iron Submersible Sewage Pump

The UT Series pumps are compact economical cast iron pumps. It features a large passage ideal for applications with solids laden liquids. Available with float switches for automatic operation (50UTZ2.4S and 50UTZ2.75S).

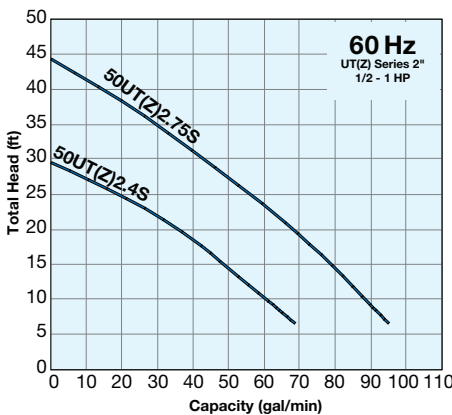

50UT2.4S



50UTZ2.4S

Dimension: 50UT2.4S/2.75S

Dimension: 50UTZ2.4S/2.75S

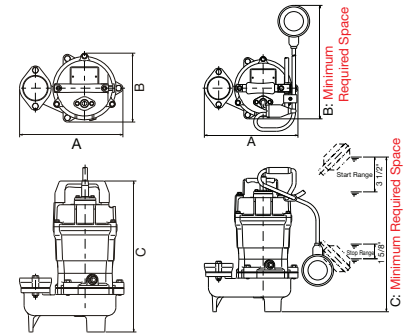

Single Phase Model	Motor Output (HP)	Rated Current (A)		*S.S. (RPM)	Discharge Size (in.)	Dimensions (in.)			Max. Solids Dia. (in.)
		115V	230V			Free Standing Models			
						A	B	C	
50UT2.4S	1/2	5.7	—	3600	2	9 1/2	6 3/8	13 3/4	1.40
50UTZ2.4S	1/2	5.7	—	3600	2	9 1/2	11 5/8 ^{*1}	15 3/4 ^{*1}	1.40
50UT2.75S	1	9.9	5.2	3600	2	9 1/2	6 3/8	16	1.40
50UTZ2.75S	1	9.9	5.2	3600	2	9 1/2	11 5/8 ^{*1}	18 ^{*1}	1.40

(Suffix Z: Automatic Operation)

* Synchronous Speed

^{*1}: Minimum Required Space

CONTROL PANELS & MOISTURE DETECTOR

■ TS SERIES CONTROL PANELS



- Lockable – 4X Enclosures
- HOA Switch – Heavy Duty Oil Tight
- Terminal Block – For Field Wiring
- Pump Run Indicator – Heavy Duty Oil Tight
- Multi-Tap Control Transformer 208 / 230 / 460 VAC Operation
- Control Alarm Fuse
- Motor Protective Switch
- Adjustable Overload Protection
- IEC Rated Magnetic Contactor
- Horn Silence Switch – Heavy Duty Oil Tight
- Auto Reset Horn Silence
- Buzzer – 95db warble
- Red Alarm Beacon
- Includes three (3) Mechanical Float Switches & Pipe Clamp

■ SEAL MOISTURE PROBE

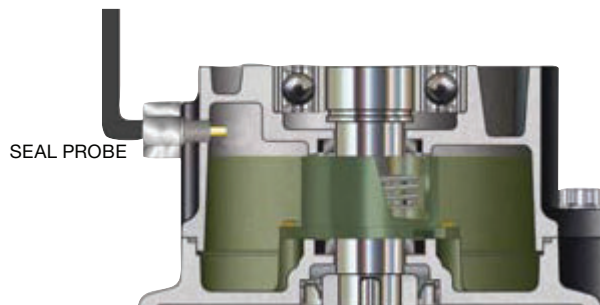

The **TSMP SEAL MOISTURE PROBE** is designed to detect moisture in the mechanical seal chamber, alerting customers of potential motor failure. The TSMP SEAL MOISTURE PROBE can be field installed on any new or existing Tsurumi pump models and connected to the control panel for the appropriate alarm or notification.

Principle of Operation:

- Sensor is installed through the oil port and directly into the mechanical seal chamber which contains an electrically non-conductive oil.
- The presence of water changes the chamber fluid mixture to a conductive condition and therefore completes the circuit which will result in a leakage indication on the control panel.

Electrical Specification

Sensor Type:	Conductive
Suggested Seal Fail Relay Voltage:	24 VAC
Required Wiring:	Single wire in separate sensor cable to be connected to seal leak relay in control panel by customer.



TSURUMI (AMERICA), INC.
 Headquarters: 1625 Fullerton Ct, Glendale Heights, IL 60139
 Utah Office: 3822 West 1987 South, Salt Lake City, UT 84104
 Tel: 1-888-878-7864 (Toll-Free) • 1-630-793-0127
 Fax: 1-630-793-0146 • www.tsurumipump.com



Your Dealer



Find us @tsurumiamerica