

ELECTRIC PUMP

EL12.5

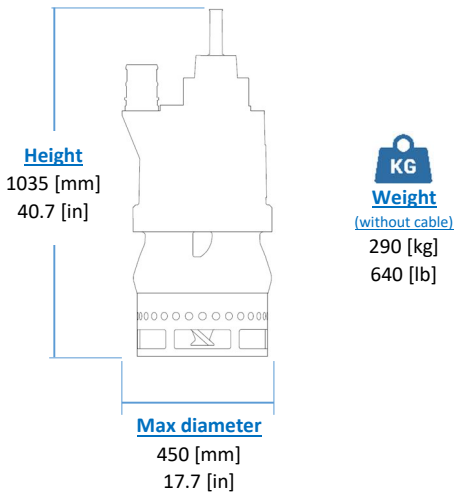
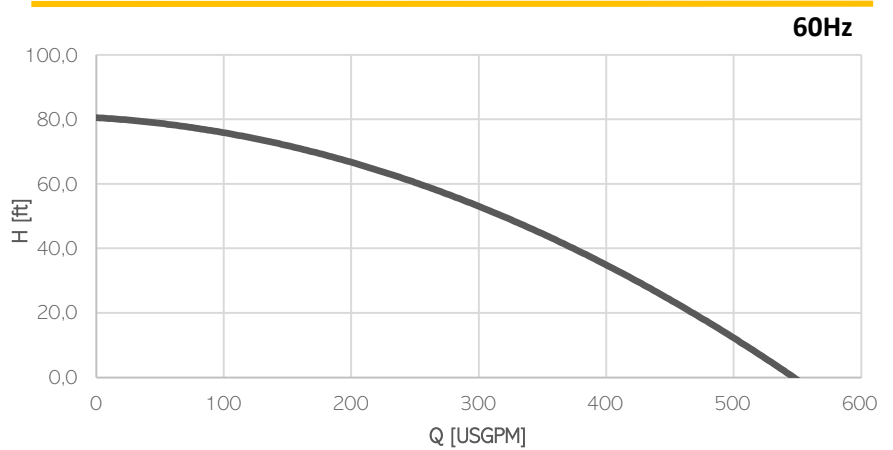

Electrical motor

Insulation class H

Cable

1 x SHD-GC cable 15m (50ft)

Operating Conditions

- Max liquid temperature 35°C
- Min Submersion depth 380mm

Model	EL12.5
Brake Power [kW HP]	9 12
Electric Power [kW HP]	10.4 14
Frequency [Hz]	60
Efficiency [%]	32
Number of Poles	4
RPM	1450
Voltage [V]	575
Rated Current [A]	13,0
Solid handling [mm in]	25 1
Discharge (Hose adaptor) [mm in]	100 4"

Materials

Part	Standard
Casing	Cast Iron EN-GJS500
Body	Cast Iron EN-GJS500
Wear Parts	High chrome EN-GJN-HV600 (CH6)
Minimum hardness [HB]	550
Main shaft	High tensile 39NiCrMo3
PH Range	5-10

Seals and lubricants

Version	STANDARD
Motor Side	MECHANICAL
Impeller Side	MECHANICAL
Oil type	ISO32