

ELECTRIC PUMP

EL35

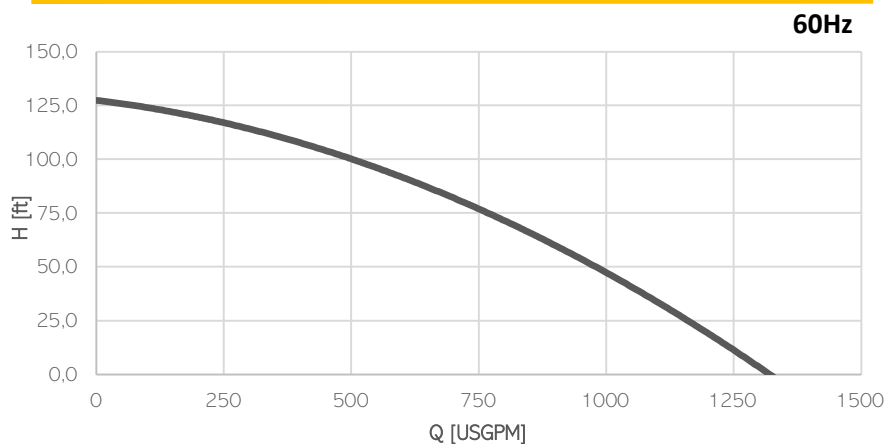

Model	EL35
Brake Power [kW HP]	26 35
Electric Power [kW HP]	28 38
Frequency [Hz]	60
Efficiency [%]	52%
Number of Poles	6
RPM	1164
Voltage [V]	575
Rated Current [A]	37,6
Solid handling [mm in]	35 1.4
Discharge [DN-PN]	100-10

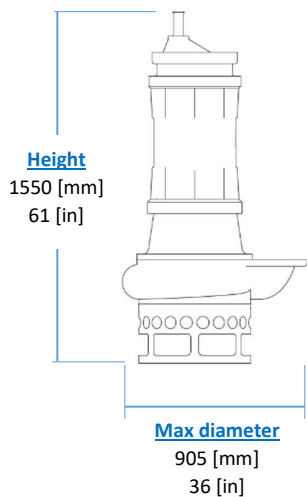

KG
Weight
(without cable)
780 [kg]
1580 [lb]

Materials

Part	Standard
Casing	Cast Iron EN-GJS500
Body	Cast Iron EN-GIL250
Wear Parts	High chrome EN-GJN-HV600 (CH6)
Minimum hardness [HB]	550
Main shaft	High tensile 39NiCrMo3
PH Range	5-10

Seals and lubricants

Version	EL35	MG	MS
Motor Side	LIPS	MECHANICAL	MECHANICAL
Impeller Side	LIPS	LIPS	MECHANICAL
Oil type	EP320	ISO32	ISO32

Electrical motor

Insulation class H

Cable

1 x SHD-GC cable 15m (50ft)

Operating Conditions

- Max liquid temperature 35°C
- Min Submersion depth 1240 mm