

ELECTRIC PUMP EL354S

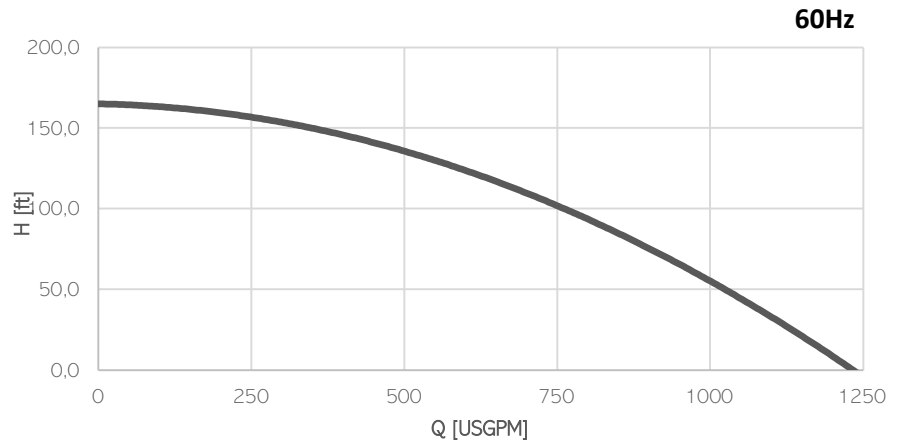

Model	EL354S
Brake Power [kW HP]	44 59
Electric Power [kW HP]	47 63
Frequency [Hz]	60
Efficiency [%]	44%
Number of Poles	4
RPM	1782
Voltage [V]	756
Rated Current [A]	63,2
Solid handling [mm in]	35 1.4
Discharge [DN-PN]	100-10

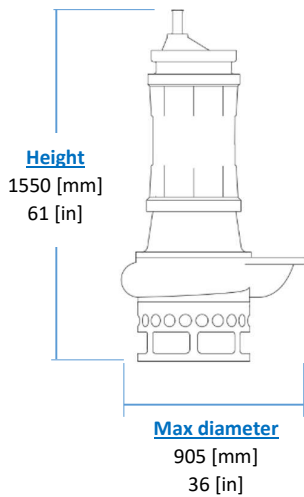

KG
Weight
(without cable)
780 [kg]
1580 [lb]

Materials

Part	Standard
Casing	Cast Iron EN-GJS800
Body	Cast Iron EN-GIL250
Wear Parts	High chrome EN-GJN-HV600 (CH6)
Minimum hardness [HB]	550
Main shaft	High tensile 39NiCrMo3
PH Range	5-10

Seals and lubricants

Version	-	MG	MS
Motor Side	-	MECHANICAL	MECHANICAL
Impeller Side	-	LIPS	MECHANICAL
Oil type	-	ISO32	ISO32

Electrical motor

Insulation class H

Cable

1 x SHD-GC cable 15m (50ft)

Operating Conditions

- Max liquid temperature 35°C
- Min Submersion depth 1240 mm