

# ELECTRIC PUMP

## EL60

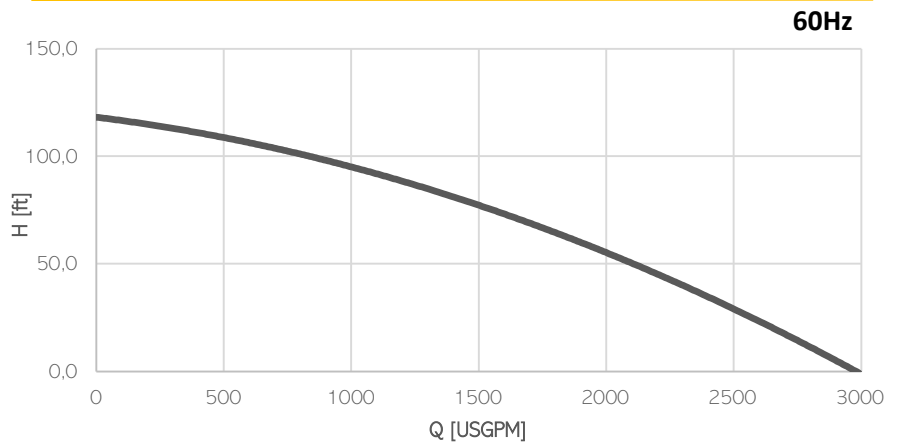

Model	EL60
Brake Power [kW HP]	45   60
Electric Power [kW HP]	49   66
Frequency [Hz]	60
Efficiency [%]	60%
Number of Poles	6
RPM	1176
Voltage [V]	575
Rated Current [A]	63,2
Solid handling [mm  in]	60   2.4
Discharge [DN-PN]	150-10

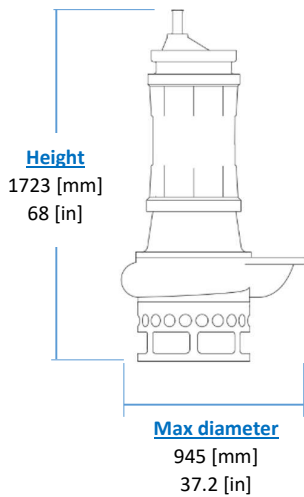

**KG**  
**Weight**  
(without cable)  
1060 [kg]  
2337 [lb]

### Materials

Part	Standard
Casing	Cast Iron EN-GJS500
Body	Cast Iron EN-GJL250
Wear Parts	High chrome EN-GJN-HV600 (CH6)
Minimum hardness [HB]	550
Main shaft	High tensile 39NiCrMo3
PH Range	5-10

### Seals and lubricants

Version	EL60	MG	MS
Motor Side	LIPS	MECHANICAL	MECHANICAL
Impeller Side	LIPS	LIPS	MECHANICAL
Oil type	EP320	ISO32	ISO32

### Electrical motor

Insulation class H

### Cable

1 x SHD-GC cable 15m (50ft)

### Operating Conditions

- Max liquid temperature 35°C
- Min Submersion depth 1510 mm