

ELECTRIC PUMP

EL606

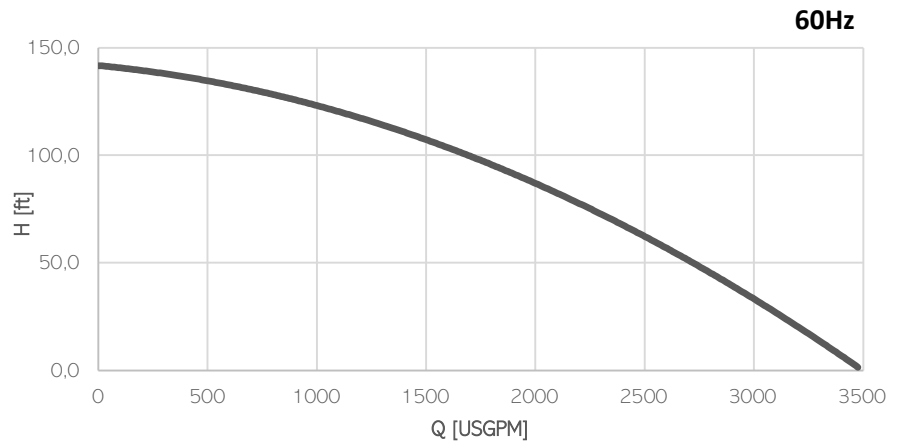

Model	EL606
Brake Power [kW HP]	75 100
Electric Power [kW HP]	80 107
Frequency [Hz]	60
Efficiency [%]	51
Number of Poles	6
RPM	1182
Voltage [V]	575
Rated Current [A]	100,0
Solid handling [mm in]	60 2.4
Discharge [DN-PN]	150-10

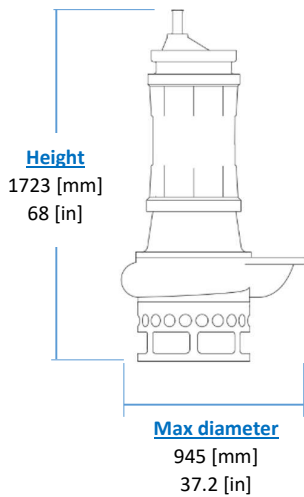

KG
Weight
(without cable)
1250 [kg]
2755 [lb]

Materials

Part	Standard
Casing	Cast Iron EN-GJS500
Body	Cast Iron EN-GIL250
Wear Parts	High chrome EN-GJN-HV600 (CH6)
Minimum hardness [HB]	550
Main shaft	High tensile 39NiCrMo3
PH Range	5-10

Seals and lubricants

Version	EL606	MG	MS
Motor Side	LIPS	MECHANICAL	MECHANICAL
Impeller Side	LIPS	LIPS	MECHANICAL
Oil type	EP320	ISO32	ISO32

Electrical motor

Insulation class H

Cable

1 x SHD-GC cable 15m (50ft)

Operating Conditions

- Max liquid temperature 35°C
- Min Submersion depth 1510 mm