

ELECTRIC PUMP EL606S

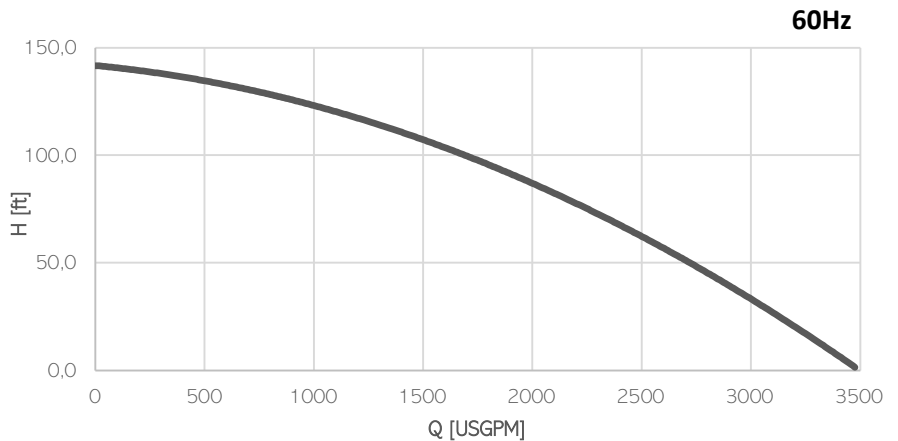

Model	EL606
Brake Power [kW HP]	90 120
Electric Power [kW HP]	96 129
Frequency [Hz]	60
Efficiency [%]	51
Number of Poles	6
RPM	1182
Voltage [V]	575
Rated Current [A]	112,8
Solid handling [mm in]	60 2.4
Discharge [DN-PN]	150-10

Materials

Part	Standard
Casing	Cast Iron EN-GJS500
Body	Cast Iron EN-GJL250
Wear Parts	High chrome EN-GJN-HV600 (CH6)
Minimum hardness [HB]	550
Main shaft	High tensile 39NiCrMo3
PH Range	5-10

Seals and lubricants

Version	EL606S	MG	MS
Motor Side	LIPS	MECHANICAL	MECHANICAL
Impeller Side	LIPS	LIPS	MECHANICAL
Oil type	EP320	ISO32	ISO32

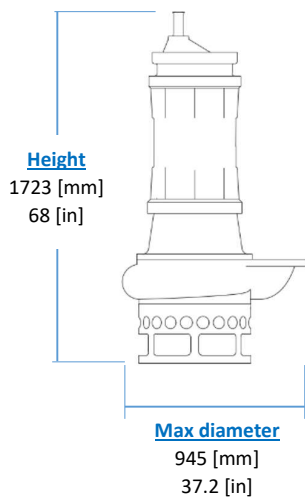

Weight
(without cable)
1280 [kg]
2820 [lb]

Electrical motor

Insulation class H

Cable

1 x SHD-GC cable 15m (50ft)

Operating Conditions

- Max liquid temperature 35°C
- Min Submersion depth 1510 mm