

ELECTRIC PUMP

EL1204

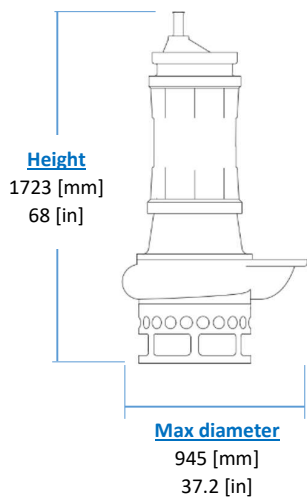
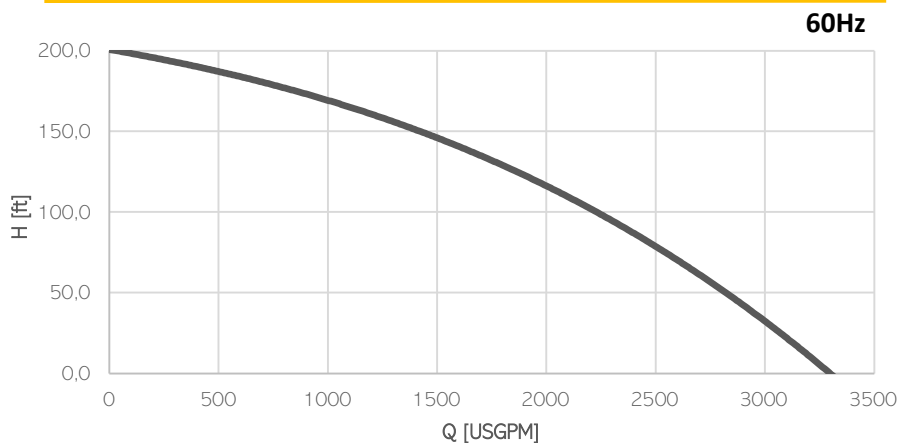

KG
Weight
(without cable)
1250 [kg]
2755 [lb]

Model	EL1204
Brake Power [kW HP]	90 120
Electric Power [kW HP]	96 128
Frequency [Hz]	60
Efficiency [%]	54%
Number of Poles	4
RPM	1776
Voltage [V]	575
Rated Current [A]	112,8
Solid handling [mm in]	60 2.4
Discharge [DN-PN]	150-10

Materials

Part	Standard
Casing	Cast Iron EN-GJS800
Body	Cast Iron EN-GJL250
Wear Parts	High chrome EN-GJN-HV600 (CH6)
Minimum hardness [HB]	550
Main shaft	High tensile 39NiCrMo3
PH Range	5-10

Seals and lubricants

Version	EL1204	MG	MS
Motor Side	LIPS	MECHANICAL	MECHANICAL
Impeller Side	LIPS	LIPS	MECHANICAL
Oil type	EP320	ISO32	ISO32

Electrical motor

Insulation class H

Cable

1 x SHD-GC cable 15m (50ft)

Operating Conditions

- Max liquid temperature 35°C
- Min Submersion depth 1510 mm