

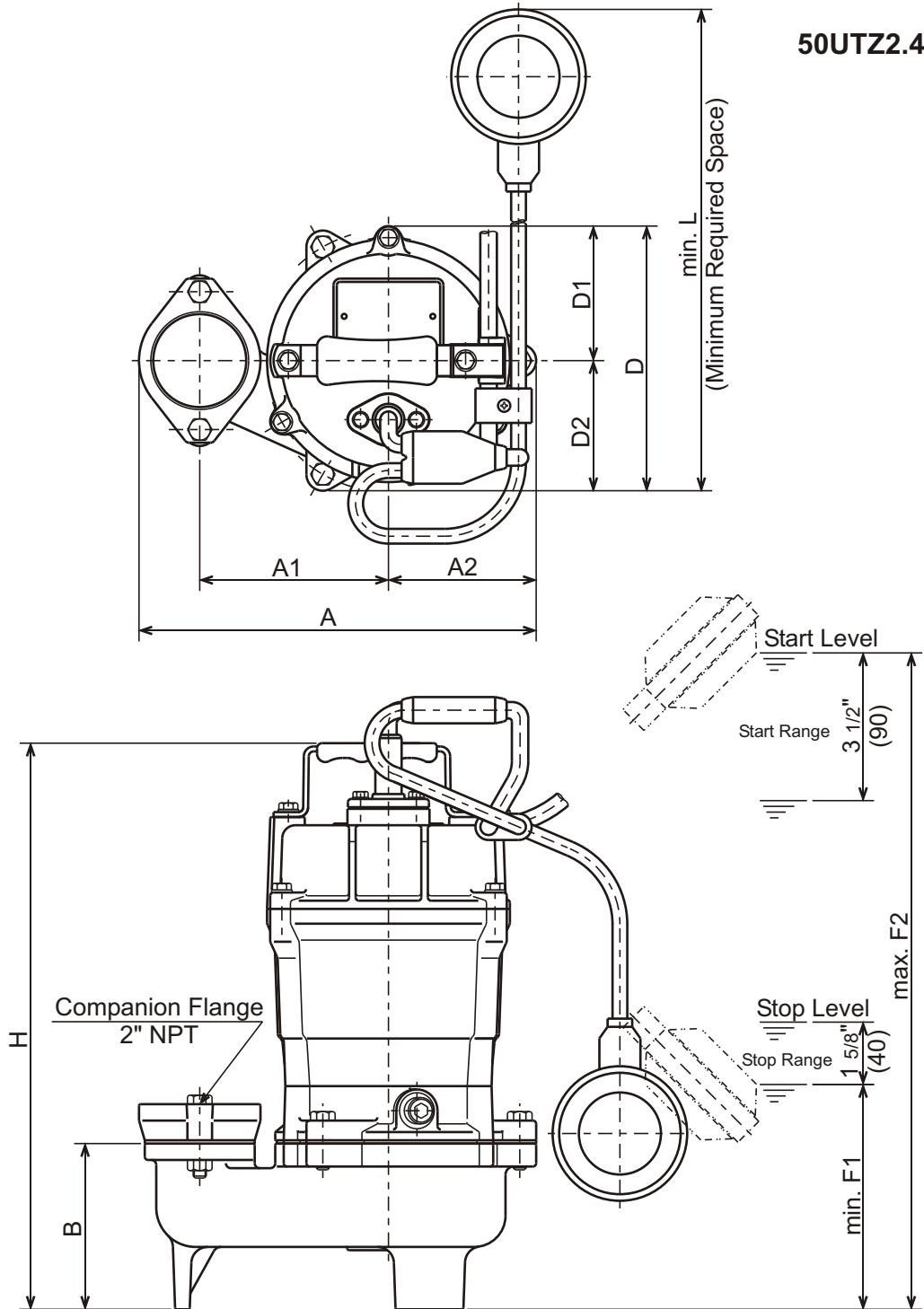

UT - SERIES
SUBMERSIBLE SEMI-VORTEX-SEWAGE PUMPS

DIMENSIONS

50UTZ2.4S-61



DIMENSIONS:USCS (Inch)

Model	HP	NOM. SIZE	Pump & Motor								Space min. L	Stop min. F1	Start max. F2	Wt. (lbs.)
			A	A1	A2	B	D	D1	D2	H				
50UTZ2.4S-61	1/2	2"	9 1/2	4 1/2	3 9/16	4	6 3/8	3 1/4	3 1/8	13 9/16	11 5/8	5 1/2	15 3/4	31

DIMENSIONS:METRIC (m m)

Model	kW	NOM. SIZE	Pump & Motor								Space min. L	Stop min. F1	Start max. F2	Wt. (kg)
			A	A1	A2	B	D	D1	D2	H				
50UTZ2.4S-61	0.40	50	242	115	90	101	161	82	79	345	293	137	400	14.0