

**150B63.7 -61**

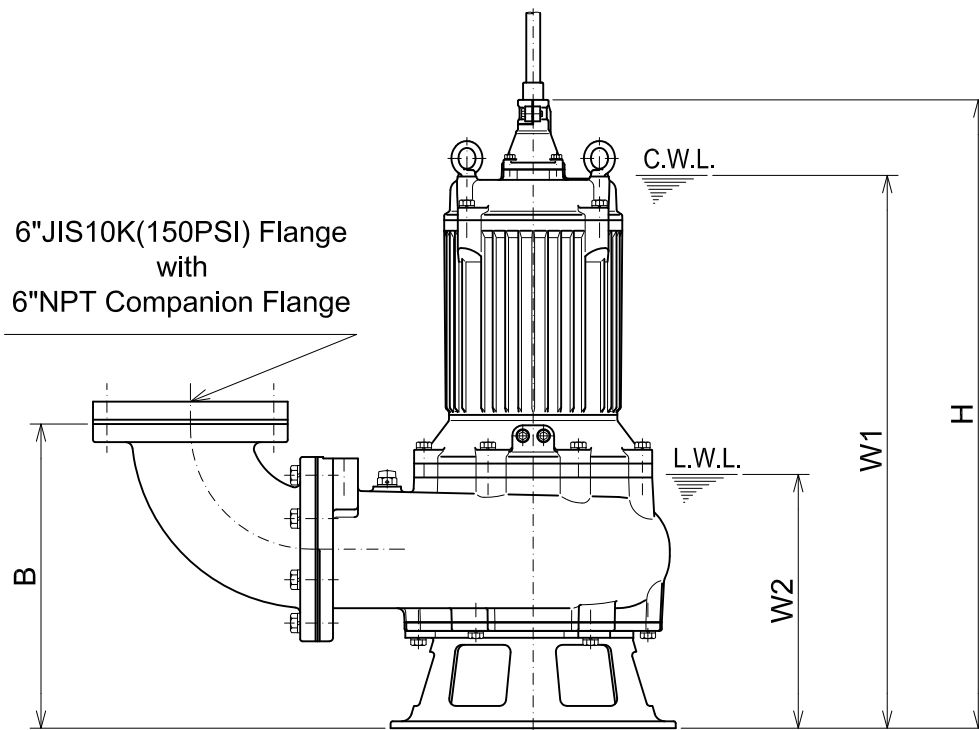
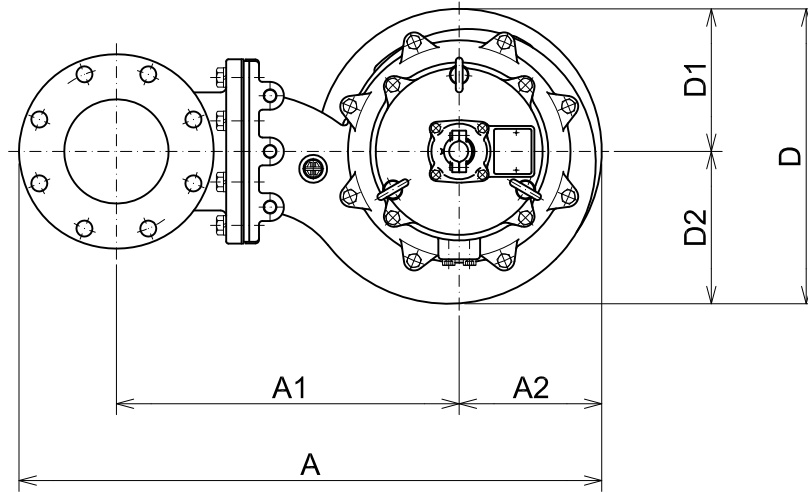

6"JIS10K(150PSI) Flange  
with  
6"NPT Companion Flange

C.W.L. :Continuous running Water Level  
L.W.L. :Lowest running Water Level

**DIMENSIONS:USCS(Inch)**

Model	HP	NOM. SIZE	Pump & Motor							C.W.L.	L.W.L.	Wt. (lbs.)	
			A	A1	A2	B	D	D1	D2				H
150B63.7 -61	5	6"	33	19 7/16	8 1/16	17 3/16	16 11/16	8 1/16	8 5/8	35 9/16	29 1/2	15	414

**DIMENSIONS:METRIC(mm)**

Model	kW	NOM. SIZE	Pump & Motor							C.W.L.	L.W.L.	Wt. (kg)	
			A	A1	A2	B	D	D1	D2				H
150B63.7 -61	3.7	150	838	493	205	437	424	205	219	903	750	380	188