

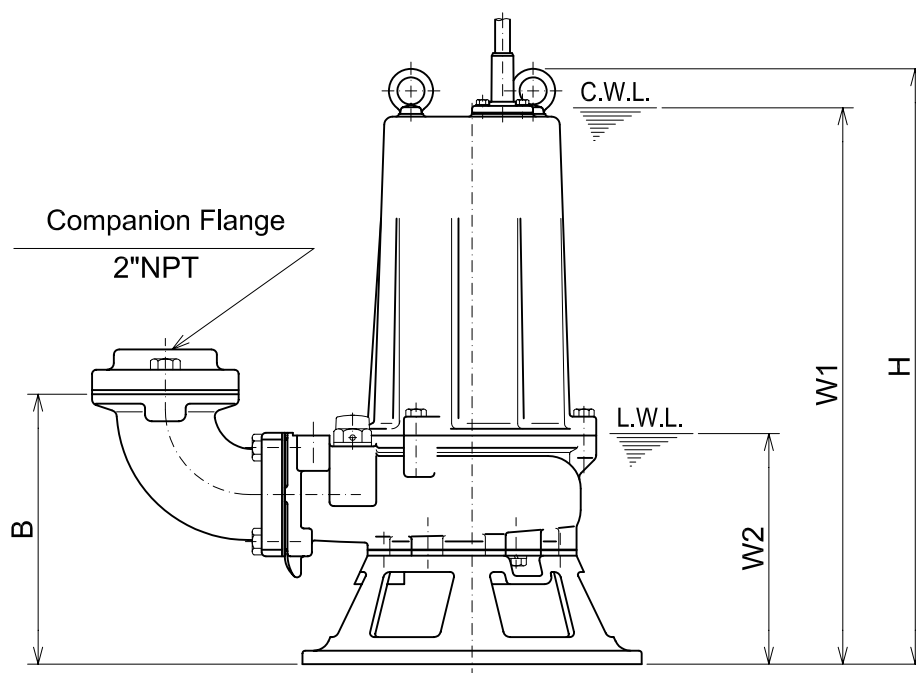

**B-SERIES**  
SEWAGE & WASTEWATER PUMPS

**DIMENSIONS**

50B2.75 -63

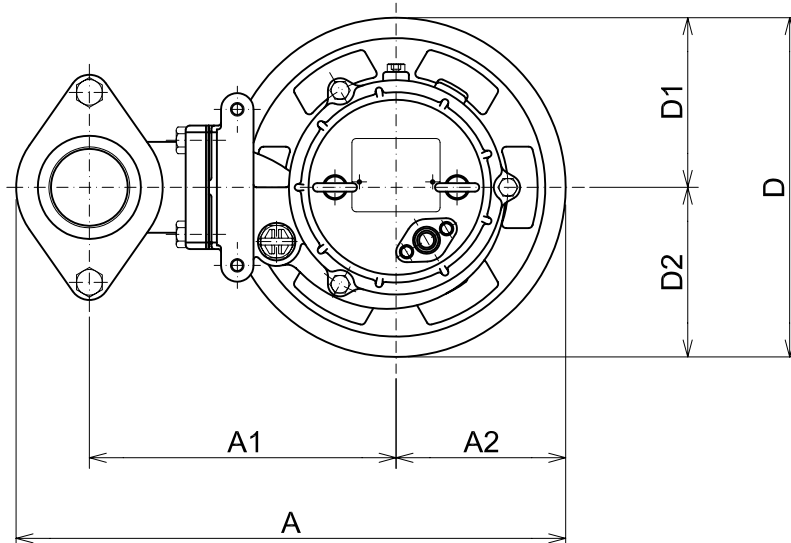

C.W.L. :Continuous running Water Level  
L.W.L. :Lowest running Water Level

**DIMENSIONS:USCS(Inch)**

Model	HP	NOM. SIZE	Pump & Motor							C.W.L.	L.W.L.	Wt. (lbs.)	
			A	A1	A2	B	D	D1	D2	H	W1		W2
50B2.75 -63	1	2"	15 15/16	8 7/8	4 15/16	7 13/16	9 13/16	4 15/16	4 15/16	17 5/16	16 1/8	6 3/4	55

**DIMENSIONS:METRIC(mm)**

Model	kW	NOM. SIZE	Pump & Motor							C.W.L.	L.W.L.	Wt. (kg)	
			A	A1	A2	B	D	D1	D2	H	W1		W2
50B2.75 -63	0.75	50	405	226	125	199	250	125	125	439	410	170	25