



TSURUMI PUMP

**C-SERIES
CUTTER - TYPE - SEWAGE & WASTEWATER PUMPS**

DIMENSIONS

50C2.75S-CR -62

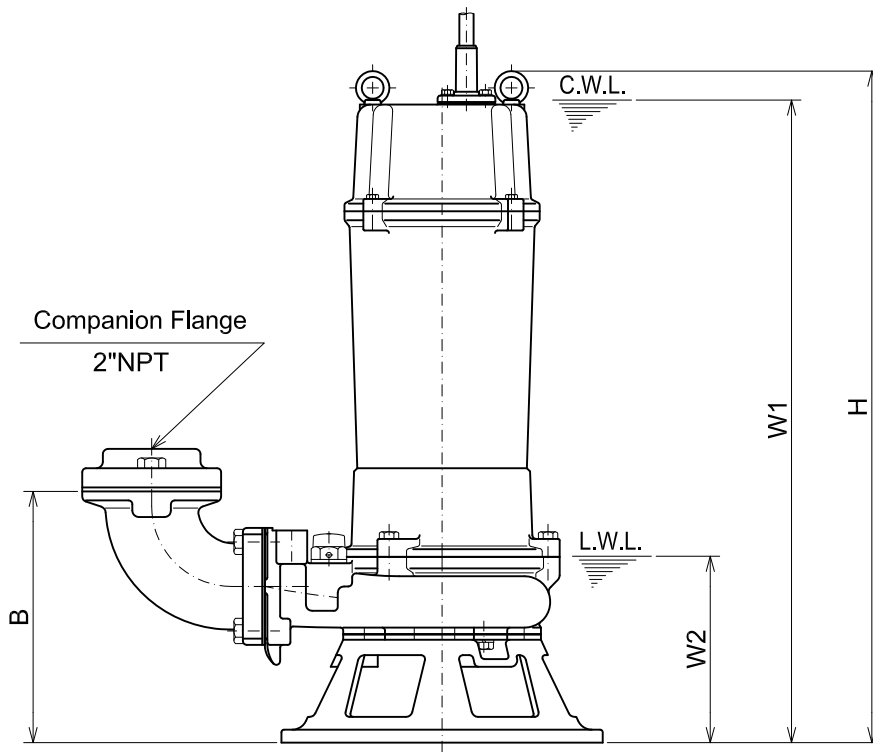
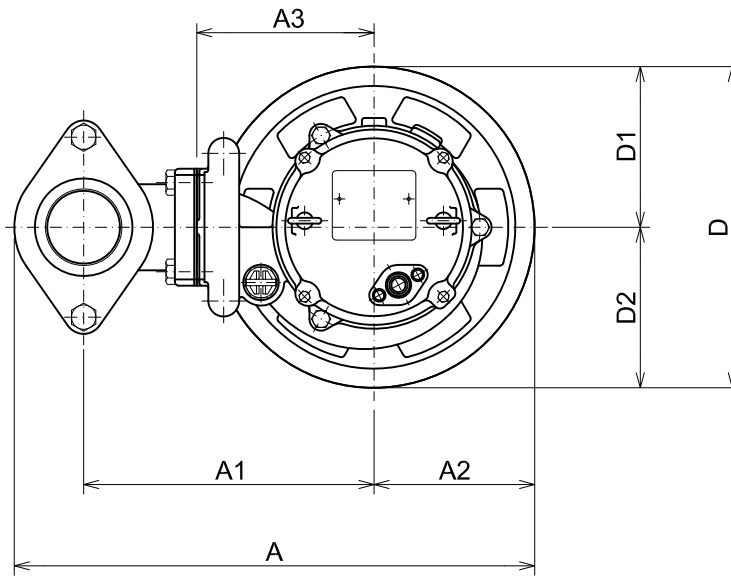

C.W.L. :Continuous running Water Level
L.W.L. :Lowest running Water Level

DIMENSIONS:USCS(Inch)

Model	HP	NOM. SIZE	Pump & Motor									C.W.L.	L.W.L.	Wt. (lbs.)
			A	A1	A2	A3	B	D	D1	D2	H			
50C2.75S-CR -62	1	2"	15 15/16	8 7/8	4 15/16	5 7/16	7 11/16	9 13/16	4 15/16	4 15/16	20 9/16	19 5/8	5 3/4	71

DIMENSIONS:METRIC(mm)

Model	kW	NOM. SIZE	Pump & Motor									C.W.L.	L.W.L.	Wt. (kg)
			A	A1	A2	A3	B	D	D1	D2	H			
50C2.75S-CR -62	0.75	50	405	226	125	138	196	250	125	125	523	500	145	32

*Excluding Cable.