



**TSURUMI PUMP**

**C-SERIES  
CUTTER - TYPE - SEWAGE & WASTEWATER PUMPS**

**DIMENSIONS**

**50C4.75-CR -63**

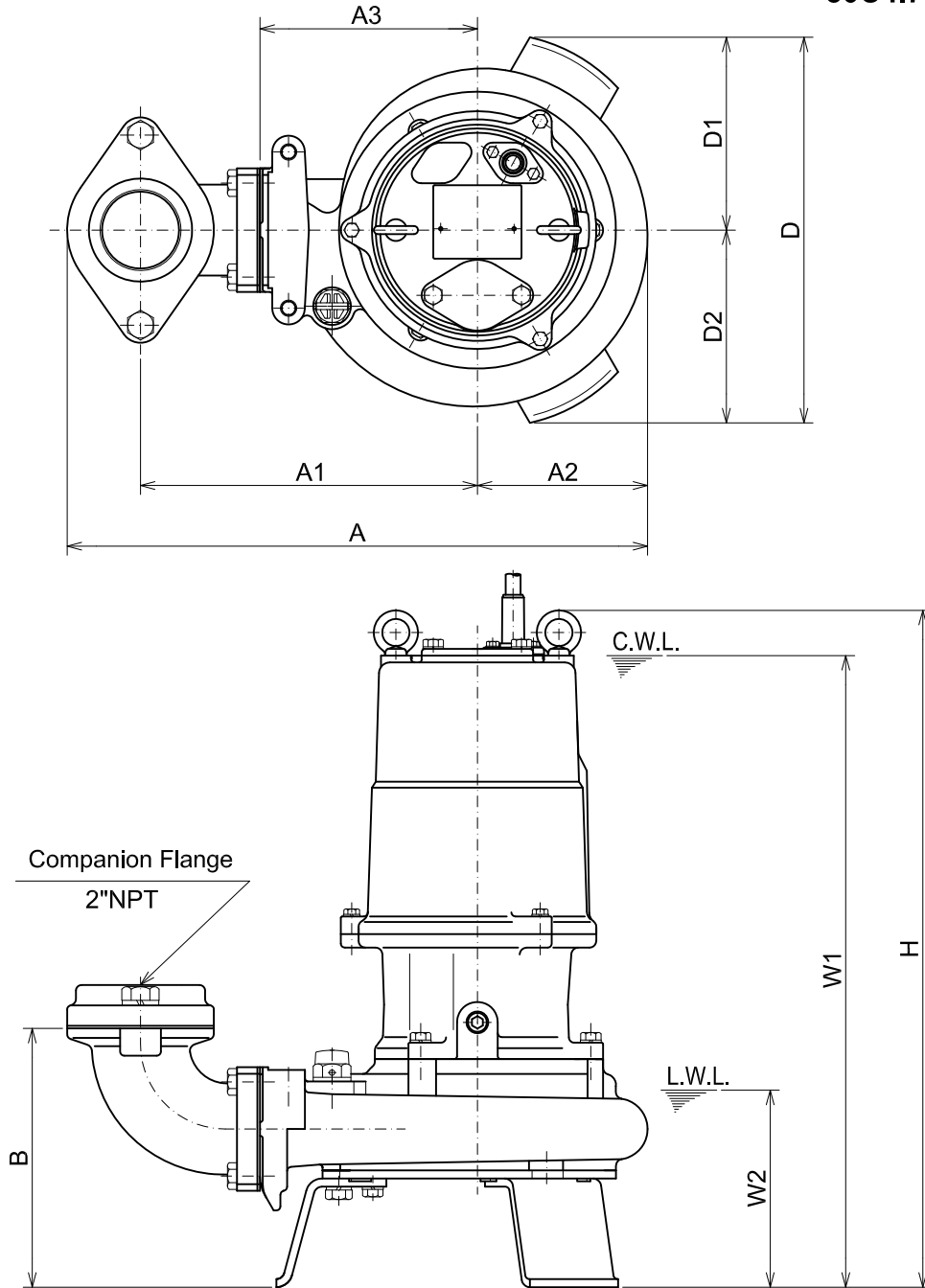

C.W.L. :Continuous running Water Level  
L.W.L. :Lowest running Water Level

**DIMENSIONS:USCS(Inch)**

Model	HP	NOM. SIZE	Pump & Motor									C.W.L. W1	L.W.L. W2	Wt. (lbs.)
			A	A1	A2	A3	B	D	D1	D2	H			
50C4.75-CR -63	1	2"	16 13/16	9 3/4	4 15/16	6 5/16	7 1/2	11 3/16	5 9/16	5 9/16	19 5/8	18 1/4	5 3/4	104

**DIMENSIONS:METRIC(mm)**

Model	kW	NOM. SIZE	Pump & Motor									C.W.L. W1	L.W.L. W2	Wt. (kg)
			A	A1	A2	A3	B	D	D1	D2	H			
50C4.75-CR -63	0.75	50	427	248	125	160	191	284	142	142	499	465	145	47