

80C211-CR -61

Bend model:
BEND80-80 ANSI

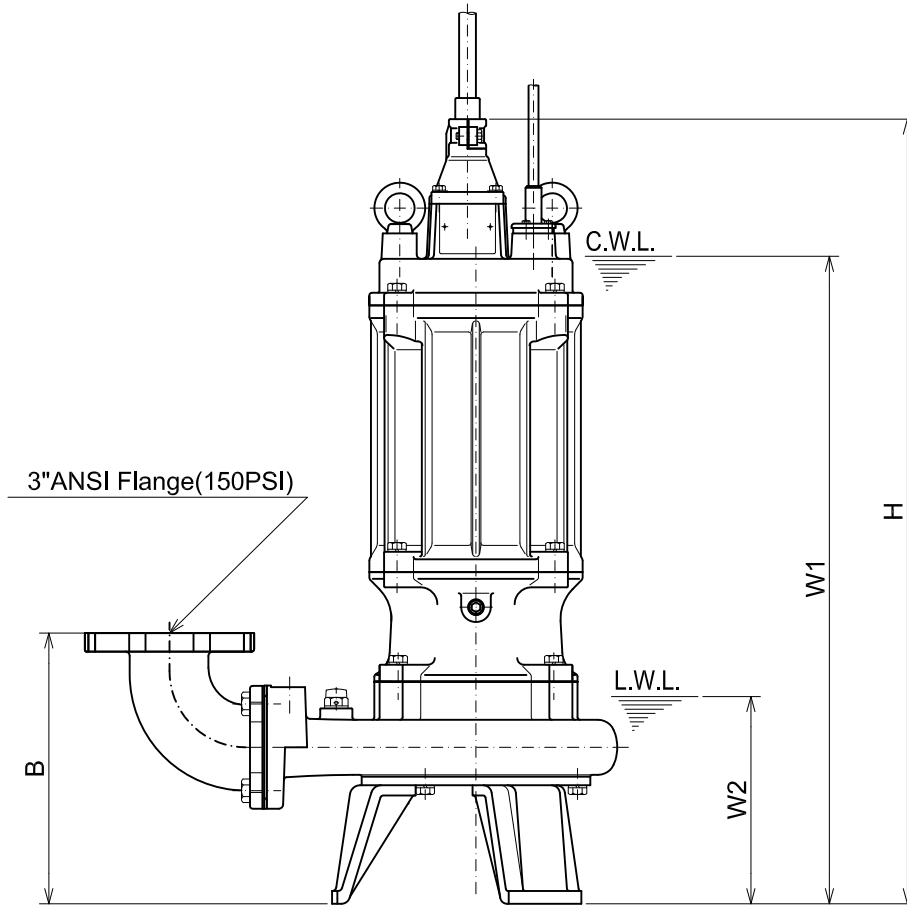
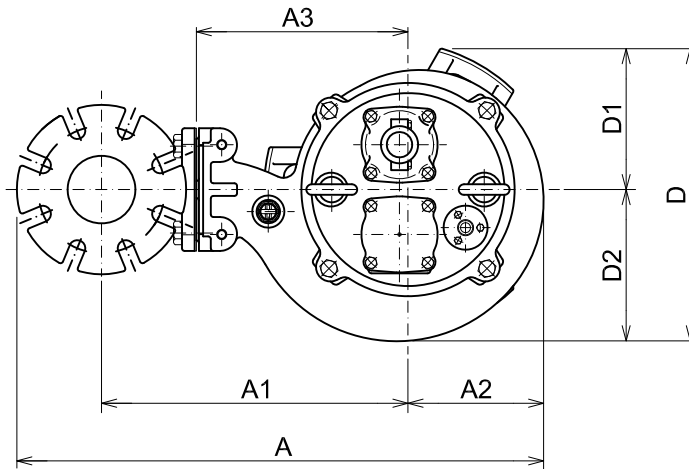

C.W.L. :Continuous running Water Level
L.W.L. :Lowest running Water Level

DIMENSIONS:USCS(Inch)

Model	HP	NOM. SIZE	Pump & Motor									C.W.L.	L.W.L.	*Wt. (lbs.)
			A	A1	A2	A3	B	D	D1	D2	H			
80C211-CR -61	15	3"	24 15/16	14 5/8	6 5/16	9 13/16	12 5/8	13 9/16	6 9/16	7 1/16	36 1/2	30 1/8	9 5/8	348

*Excluding Cable.

DIMENSIONS:METRIC(mm)

Model	kW	NOM. SIZE	Pump & Motor									C.W.L.	L.W.L.	*Wt. (kg)
			A	A1	A2	A3	B	D	D1	D2	H			
80C211-CR -61	11	80	633	372	160	250	320	345	166	179	927	765	245	158