

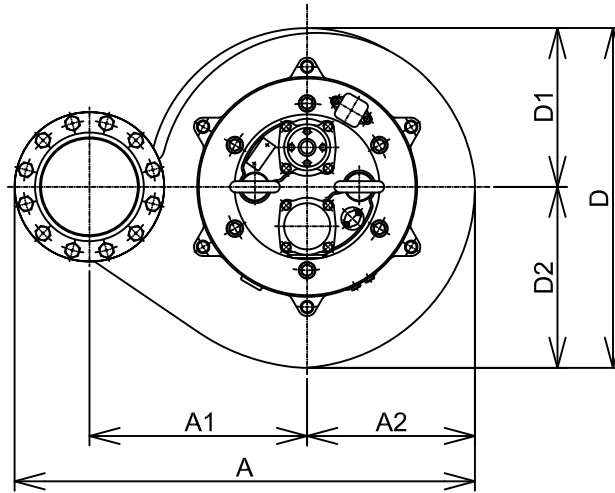

**GPN SERIES**  
SUBMERSIBLE AGITATOR PUMPS

**DIMENSIONS**

**GPN837-61**



8" JIS10K(150PSI) Flange  
with  
8"NPT Companion Flange

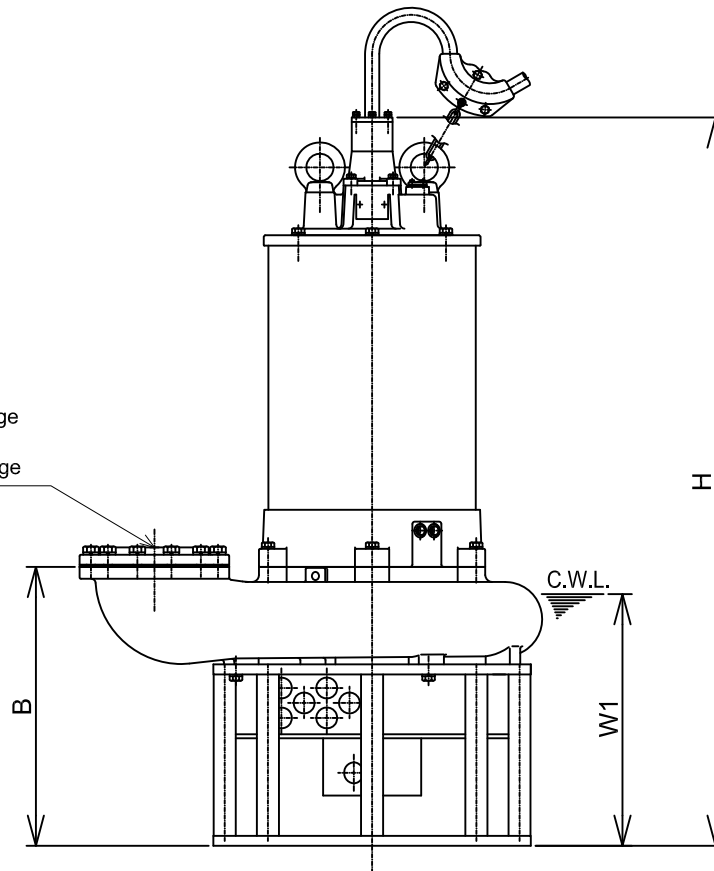

C.W.L. :Continuous running Water Level

**DIMENSIONS:USCS(Inch)**

Model	HP	NOM. SIZE	Pump & Motor								C.W.L.	*Wt.
			A	A1	A2	B	D	D1	D2	H	W1	(lbs.)
GPN837-61	50	8"	39 15/16	18 7/8	14 9/16	24 3/16	29 1/2	13 3/4	15 11/16	63 1/4	22	1760

\*Excluding Cable

**DIMENSIONS:METRIC(mm)**

Model	kW	NOM. SIZE	Pump & Motor								C.W.L.	*Wt.
			A	A1	A2	B	D	D1	D2	H	W1	(kg)
GPN837-61	37	200	1015	480	370	615	749	350	399	1606	560	800