

**GSZ5-37-6**

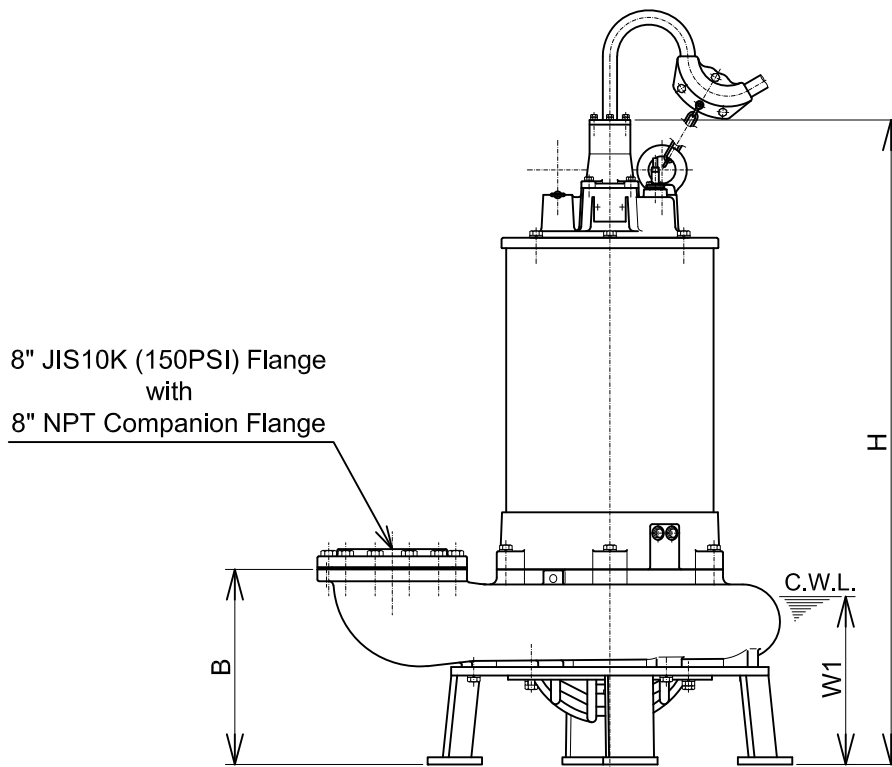
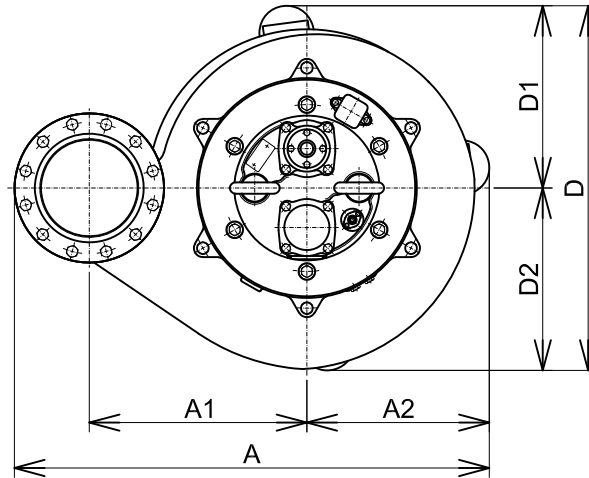

C.W.L. : Continuous running Water Level

**DIMENSIONS:USCS (Inch)**

Model	HP	NOM. SIZE	Pump & Motor								C.W.L.	*Wt.
			A	A1	A2	B	D	D1	D2	H	W1	(lbs.)
GSZ5-37-6	50	8"	41 1/4	18 7/8	15 13/16	16 15/16	31 5/8	15 13/16	15 13/16	55 15/16	14 5/8	1750

**DIMENSIONS:METRIC (mm)**

Model	kW	NOM. SIZE	Pump & Motor								C.W.L.	*Wt.
			A	A1	A2	B	D	D1	D2	H	W1	(kg)
GSZ5-37-6	37	200	1047	480	402	430	804	402	402	1421	370	796

\*Excluding Cable