

**TOS150B415 -63**

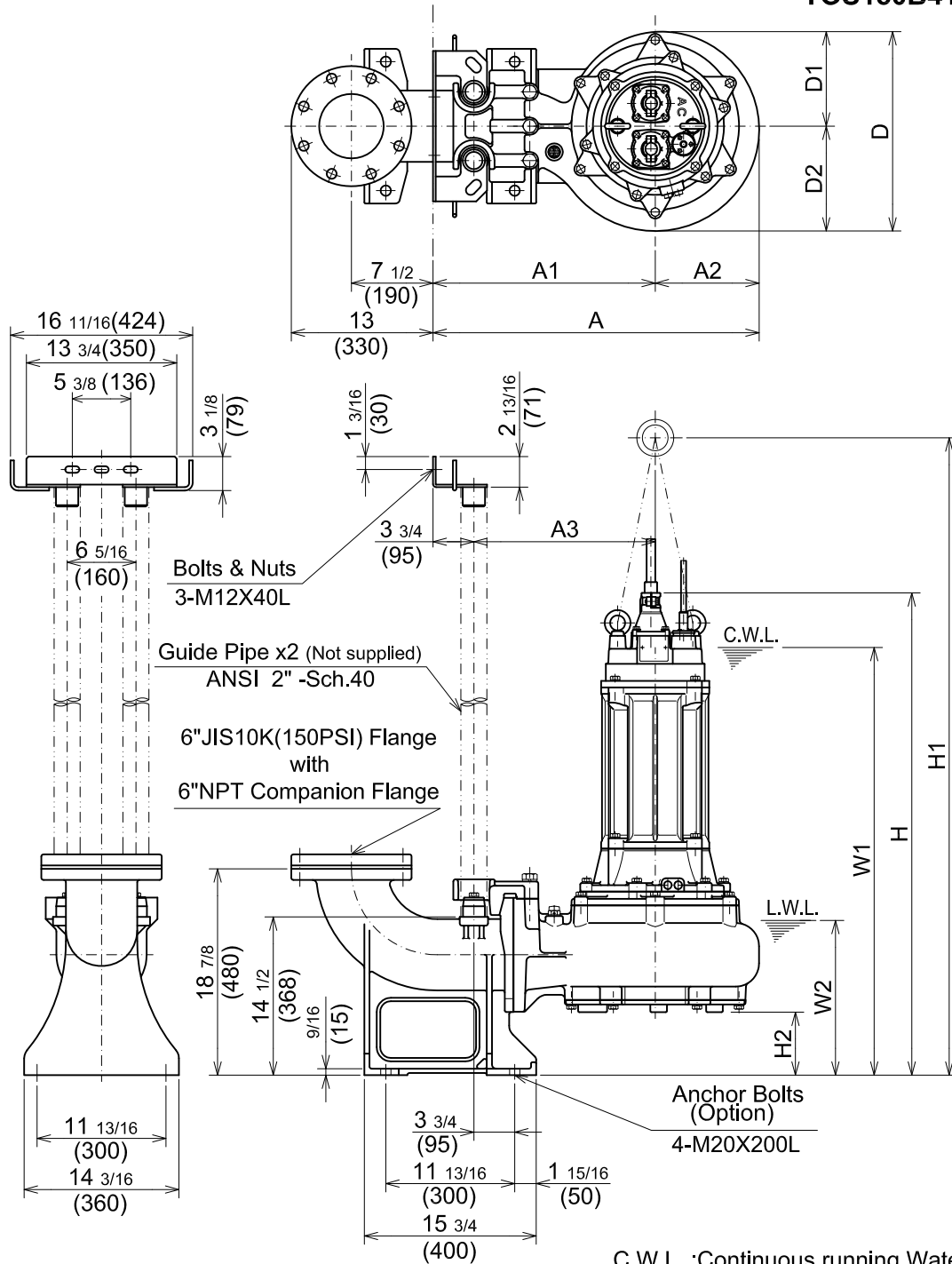

C.W.L. :Continuous running Water Level  
L.W.L. :Lowest running Water Level

**DIMENSIONS:USCS(Inch)**

Model	HP	NOM. SIZE	Pump & Motor										C.W.L.	L.W.L.	Wt. (lbs.)
			A	A1	A2	A3	D	D1	D2	H	H1	H2			
TOS150B415 -63	20	6"	29 7/8	20 3/8	9 1/2	16 5/8	18 1/4	8 11/16	9 5/8	44 3/16	58 3/8	5 13/16	39 1/8	14 1/8	530

**DIMENSIONS:METRIC(mm)**

Model	kW	NOM. SIZE	Pump & Motor										C.W.L.	L.W.L.	Wt. (kg)
			A	A1	A2	A3	D	D1	D2	H	H1	H2			
TOS150B415 -63	15	150	759	517	242	422	464	220	244	1122	1483	147	995	360	240