

TOS50B2.75S -62

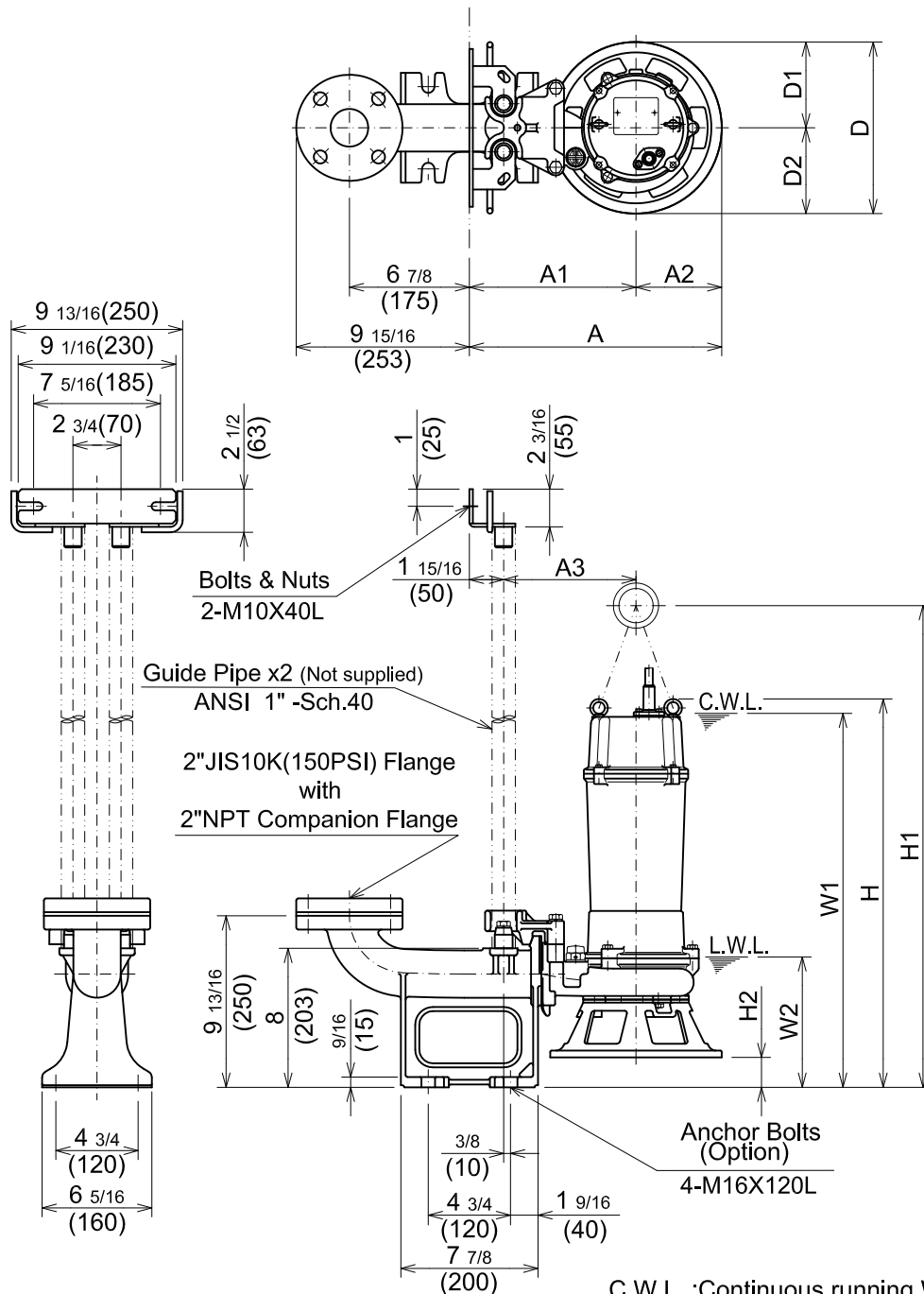

C.W.L. :Continuous running Water Level
L.W.L. :Lowest running Water Level

DIMENSIONS:USCS(Inch)

Model	HP	NOM. SIZE	Pump & Motor										C.W.L. W1	L.W.L. W2	Wt. (lbs.)
			A	A1	A2	A3	D	D1	D2	H	H1	H2			
TOS50B2.75S -62	1	2"	14 1/2	9 9/16	4 15/16	7 5/8	9 13/16	4 15/16	4 15/16	22 5/16	27 5/8	1 3/4	21 1/2	7 1/2	66

DIMENSIONS:METRIC(mm)

Model	kW	NOM. SIZE	Pump & Motor										C.W.L. W1	L.W.L. W2	Wt. (kg)
			A	A1	A2	A3	D	D1	D2	H	H1	H2			
TOS50B2.75S -62	0.75	50	368	243	125	193	250	125	125	566	702	44	545	190	30