



TSURUMI PUMP

**MG-SERIES
GRINDER PUMPS**

DIMENSIONS

TOS50MG23.7 -63

**Guide Rail System
Model : TOSH-50**

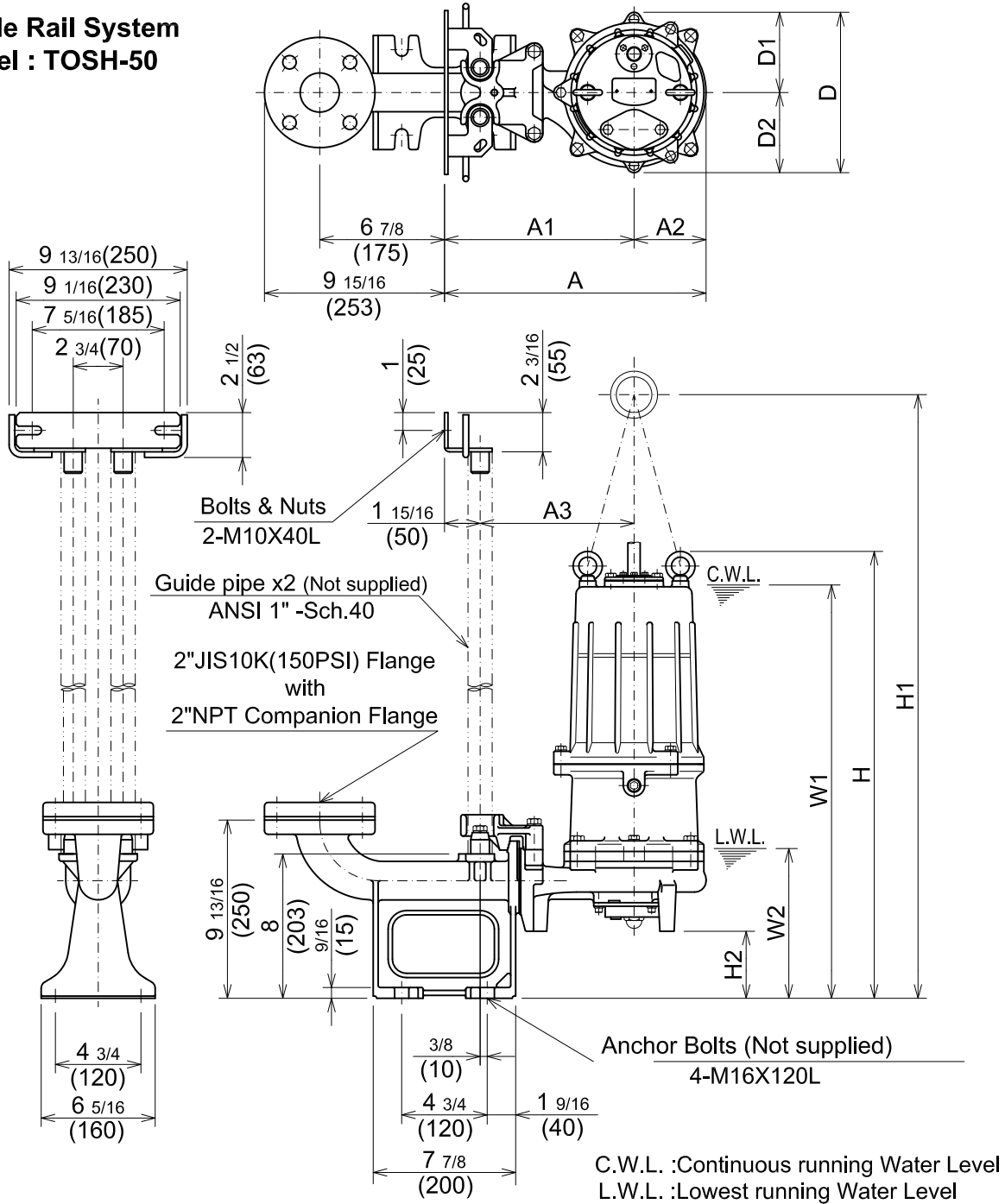

DIMENSIONS:USCS(Inch)

Model	HP	NOM. SIZE	Pump & Motor									C.W.L.	L.W.L.	*Wt. (lbs.)	
			A	A1	A2	A3	D	D1	D2	H	H1				H2
TOS50MG23.7 -63	5	2"	14 7/16	10 1/2	4	8 1/2	8 7/8	4 7/16	4 7/16	24 11/16	33 3/8	3 11/16	22 7/8	8 1/4	163

DIMENSIONS:METRIC(mm)

Model	kW	NOM. SIZE	Pump & Motor									C.W.L.	L.W.L.	*Wt. (kg)	
			A	A1	A2	A3	D	D1	D2	H	H1				H2
TOS50MG23.7 -63	3.7	50	367	266	101	216	225	113	113	627	847	94	580	210	74

*Excluding Cable & TOS