

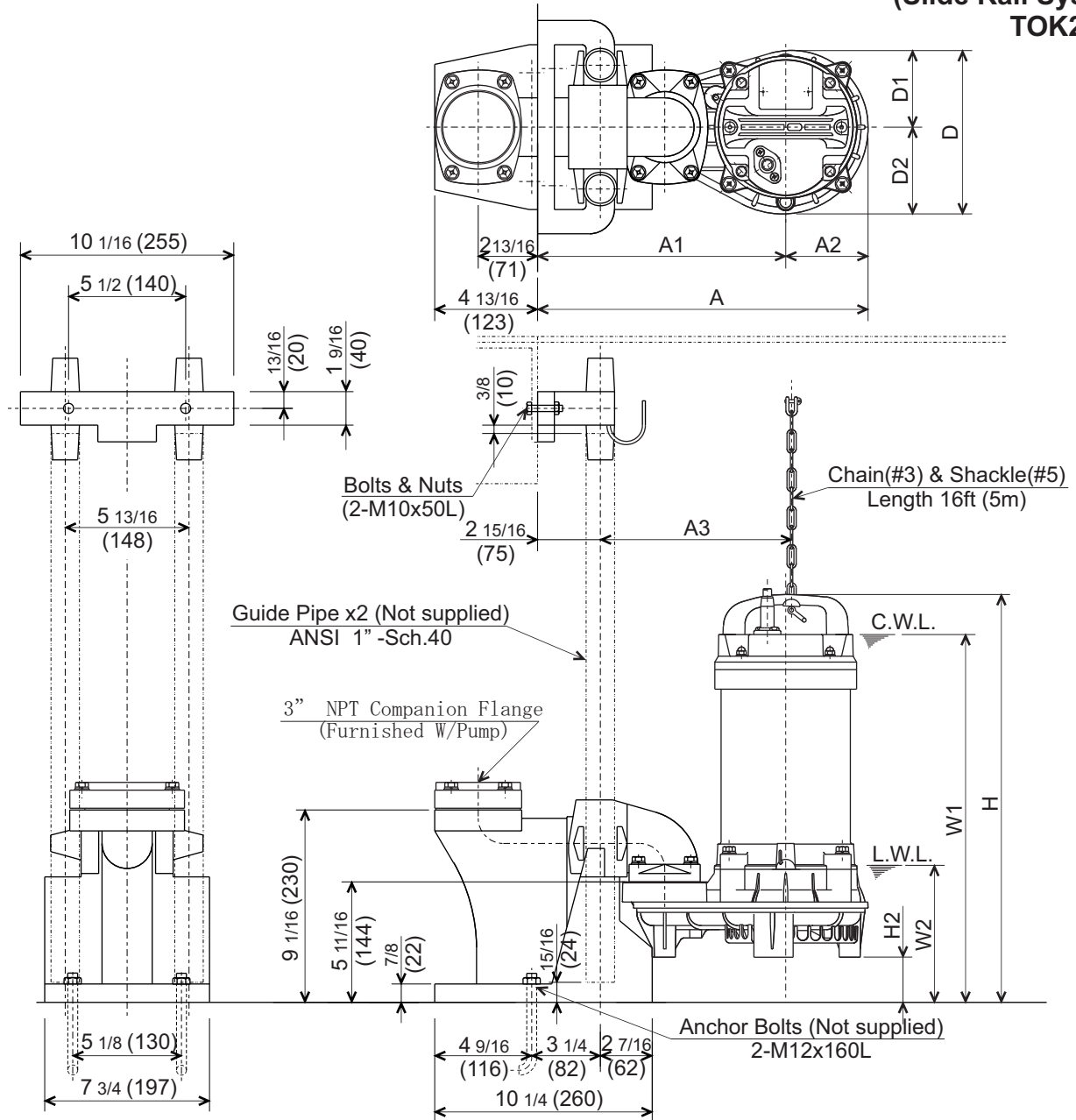

VANCS-SERIES - PSF
(FRP) EFFLUENT PUMPS

DIMENSIONS

TOK80PSF21.5
(Slide Rail System
TOK2-65)



C.W.L. : Continuous running Water Level
L.W.L. : Lowest running Water Level

DIMENSIONS:USCS (Inch)

Model	HP	NOM. SIZE	Pump & Motor								C.W.L. W1	L.W.L. W2	Wt. (lbs.)	
			A	A1	A2	A3	D	D1	D2	H				
TOK80PSF21.5	2	3"	15 9/16	11 11/16	3 7/8	9 1/16	7 11/16	3 5/8	4 1/8	19 1/4	2 1/8	17 3/8	6 1/2	34.8

DIMENSIONS:METRIC (mm)

Model	kW	NOM. SIZE	Pump & Motor								C.W.L. W1	L.W.L. W2	Wt. (kg)	
			A	A1	A2	A3	D	D1	D2	H				
TOK80PSF21.5	1.5	80	396	297	99	231	196	92	104	489	54	441	164	15.8