



UZ-SERIES
VORTEX - SEWAGE & WASTEWATER PUMPS

DIMENSIONS

TOS80UZ411 -64

Guide Rail System
 Model : TOS3-80-80 ANSI
 Wt. : 64lb. (29kg)

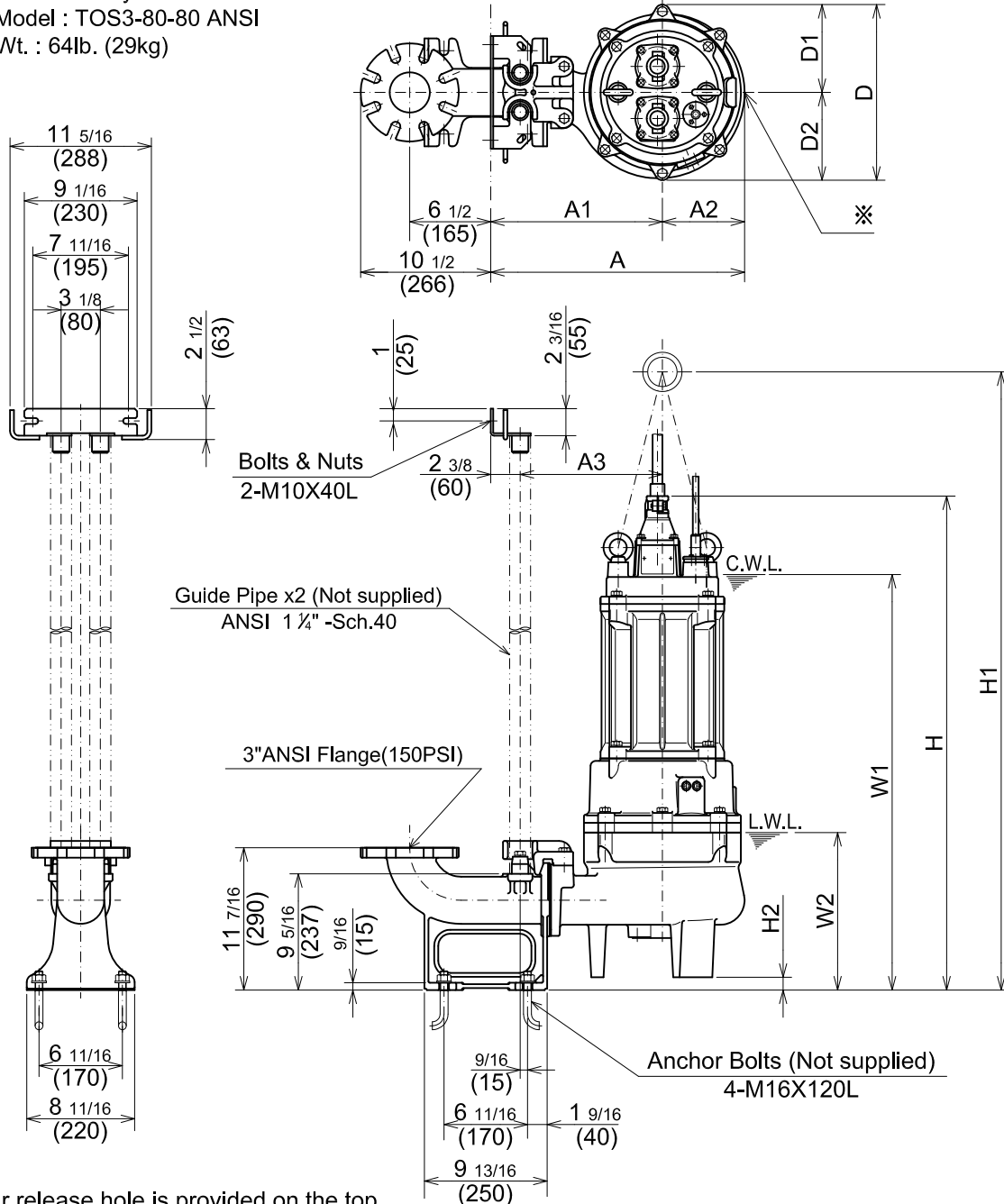

※An air release hole is provided on the top of the pump casing.

C.W.L. :Continuous running Water Level
 L.W.L. :Lowest running Water Level

DIMENSIONS:USCS(Inch)

Model	HP	NOM. SIZE	Pump & Motor									C.W.L.	L.W.L.	*Wt. (lbs.)	
			A	A1	A2	A3	D	D1	D2	H	H1				H2
TOS80UZ411 -64	15	3"	20 3/8	13 3/4	6 5/8	11 7/16	14 1/8	7 1/16	7 1/16	39 5/8	52 11/16	1	33 1/2	12 3/4	377

DIMENSIONS:METRIC(mm)

Model	kW	NOM. SIZE	Pump & Motor									C.W.L.	L.W.L.	*Wt. (kg)	
			A	A1	A2	A3	D	D1	D2	H	H1				H2
TOS80UZ411 -64	11	80	518	350	168	290	358	179	179	1007	1338	26	850	325	171

*Excluding TOS & Cable.