

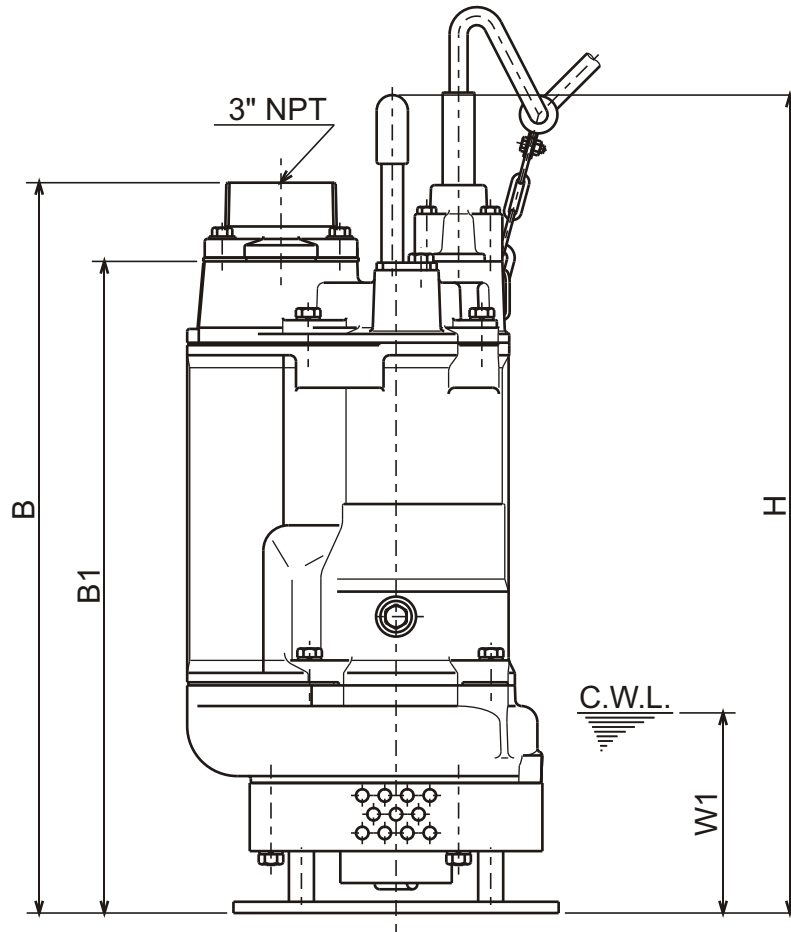

KTD - SERIES
SUBMERSIBLE AGITATOR PUMPS

DIMENSIONS

KTD33.0-63

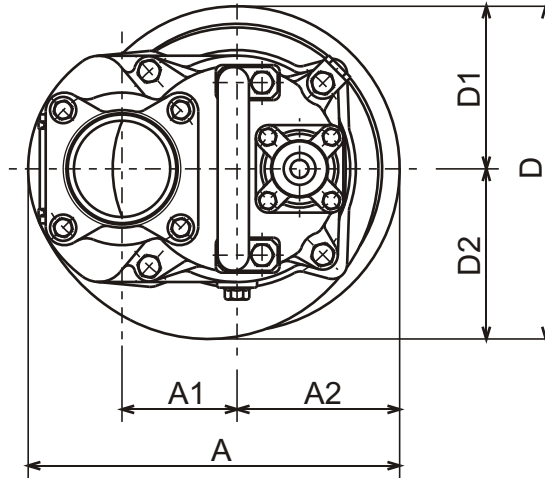

C.W.L. : Continuous running Water Level

DIMENSIONS:USCS (In ch)

Model	HP	NOM. SIZE	Pump & Motor									C.W.L.	*Wt.
			A	A1	A2	B	B1	D	D1	D2	H	W1	(lbs.)
KTD33.0-63	4	3"	11 11/16	3 5/8	5 1/8	23	20 1/2	10 1/2	5 1/8	5 3/8	25 3/4	6 1/4	145

DIMENSIONS:METRIC (mm)

Model	kW	NOM. SIZE	Pump & Motor									C.W.L.	*Wt.
			A	A1	A2	B	B1	D	D1	D2	H	W1	(kg)
KTD33.0-63	3.0	80	297	92	130	584	521	266	130	136	654	160	66

*Excluding Cable