

PARTS LIST		CONTRACTOR PUMPS			6/18/2012	
ITEM	PART No.	DESCRIPTION	QTY	SIZE	MATERIAL	NOTES
1		Cabtyre Cable Set				
1	001-102-48	Cabtyre Cable Set (6m)220V-60Hz	1	VCT4Cx1.25mm2	LBT	
1	001-102-48	Cabtyre Cable Set (6m)380V-50Hz	1	VCT4Cx1.25mm2	LBT	
1	001-102-48	Cabtyre Cable Set (6m)380V-50Hz(THA)	1	VCT4Cx1.25mm2	LBT	
1	001-102-48	Cabtyre Cable Set (6m)380V-60Hz	1	VCT4Cx1.25mm2	LBT	
1	001-102-48	Cabtyre Cable Set (6m)400/415V-50Hz	1	VCT4Cx1.25mm2	LBT	
1	001-102-48	Cabtyre Cable Set (6m)440V-60Hz	1	VCT4Cx1.25mm2	LBT	
1	001-006-87	Cabtyre Cable Set (10m)400/415V-50Hz(EUR)	1	H07RN4Cx1.5mm2(CEE,Gray)	LBT(HAR)	
1	001-803-20	Cabtyre Cable Set (10m)220V-60Hz(USA)	1	VCT4Cx1.25mm2	LBT	
1	001-803-20	Cabtyre Cable Set (10m)440V-60Hz(USA)	1	VCT4Cx1.25mm2	LBT	
2	140-427-17	Hex.Bolt (w/Plain Washer)	2	M5x15	SUS304	
3	003-190-10	Gland	1		SUS316	
4	072-105-25	Eye Bolt	2	M8	SUS304	
5	064-279-26	Motor Frame (2nd)	1		FC	
6	140-076-17	Hex.Bolt	3	M10x30	SUS304	
7	009-112-16	Earth Terminal	1Set	1.25mm2		
8	142-124-20	Plain Washer	1	M4	SPC	
9	143-086-22	Pan Screw (w/Spring Washer)	1	M4x8	SWRM	
10	142-195-19	Wave Washer	1	6204/6303(d47x.0.3t)	SK5	
11	052-103-18	Bearing (1st)	1	6204ZZC3		
11	052-187-16	Bearing (w/O-ring)(2nd)	1	AC-6204ZZC3		
12	058-116-12	Lead Wire Protection Plate	1	d60xd150x1t	Bakelite	
13		Stator (2nd)				
14	127-104-14	Protector Fixing Plate	1	15-BE2	SECC	
15		Motor Protector				
15	053-204-26	Motor Protector 220V-60Hz	1	KA313-GCTL103	(T)	
15	053-380-14	Motor Protector 380V-50Hz	1	KA313-GQVL102	(T)	
15	053-380-14	Motor Protector 400/415V-50Hz	1	KA313-GQVL102	(T)	
15	053-380-14	Motor Protector 400/440V-60Hz	1	KA313-GQVL102	(T)	
15	053-378-19	Motor Protector 440/460/480V-60Hz	1	KA313-GQVL104	(T)	
15	053-379-10	Motor Protector 525V-50Hz	1	KA313-GQVL116	(T)	
16	142-124-20	Plain Washer	2	M4	SPC	
17	143-016-18	Pan Screw	2	M4x12	SWRM	
18	055-737-16	Rotor (2nd)	1Set	w/Bearing		
19	147-038-18	Impeller Key	1	5x5x15.5l	SUS420	
20	061-161-12	Bearing Collar	1	d25.1xd36x1.6t	SPC	
21	143-028-13	Pan Screw	2	M5x10	SWRM	
22	062-187-17	Bearing Fixing Washer	2	d5.5xd18x2.3t	SPC	
23	052-108-13	Bearing	1	6305ZZC3		
24	146-015-16	Retaining Ring	1	C25	SK5	
25	060-231-11	Bearing Housing	1		FC	
26	025-252-19	Mechanical Seal	1	H-20A	SiC+CCBN	
27	143-070-23	Pan Screw	2	M5x6	SWRM	
28	030-144-13	Oil Lifter	1	H-20(A)(T)	Resin	

PARTS LIST		CONTRACTOR PUMPS				6/18/2012
ITEM	PART No.	DESCRIPTION	QTY	SIZE	MATERIAL	NOTES

EXPLODED VIEW

80C21.5-51/61 (15-OE2)

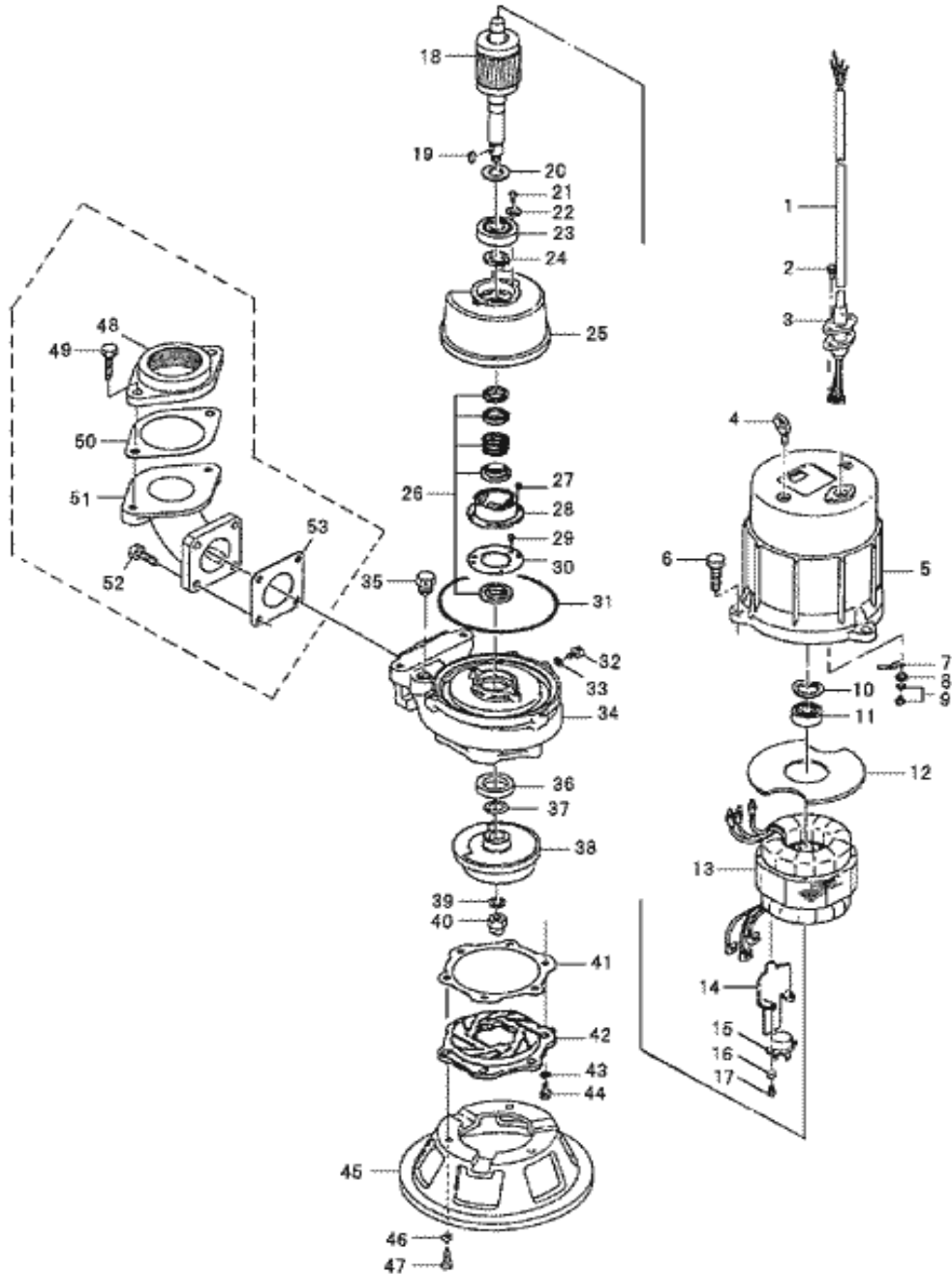

C-01450-1