

PARTS LIST		AGITATOR PUMP			11/8/2019	
ITEM	PART No.	DESCRIPTION	QTY	SIZE	MATERIAL	NOTES
1	001-509-36	Cabtyre Cable Set (50') 60Hz (USA)	1	2PNCTF4Cx3.5mm2	KR-2	interchangable w/OLD# 001-312-30
2	006-126-14	Stuffing Box 60Hz (USA)	1	No.2	FC	included in ITEM 1 cable assembly
3	140-055-10	Hex.Bolt	4	M8x25	SUS304	
4	070-107-18	Cable Clamp	1		FC	included in ITEM 1 cable assembly
5	140-035-14	Hex.Bolt	2	M6x20	SUS304	included in ITEM 1 cable assembly
6	008-143-13	Mould Cover 60Hz (USA)	1	KR2-8	CR	included in ITEM 1 cable assembly
7	010-120-18	Cable Clip	1	No.2-1	SPC	
8	010-121-19	Cable Clip Rubber	1	No.1	NBR	
9	141-004-17	Hex.Nut	1	M6	SUS304	
10	140-033-12	Hex.Bolt	1	M6x15	SUS304	
11	095-000-95	Chain	1	4mm(4L)	SS	replaces OLD# 095-131-18 (3L)
12	011-110-11	Shackle	1	6mm(M8,SC)	SS	
13	140-081-15	Hex.Bolt	4	M10x50	SUS304	
14	142-164-19	Spring Washer	4	M10	SUS304	
15	142-128-24	Plain Washer	1	M10	SPC	
16	070-103-10	L-Shape Fitting	1	KT-55	SPC	
17	009-123-10	Terminal	3	P-5.5	CU	included in ITEM 1 cable assembly
18	009-101-12	Terminal(C/W Screw)	3	d12x(d6.6xd6.6)x25l	C3604	
19	009-123-10	Terminal	3	P-5.5	CU	
20	002-129-15	Heat Shrink Tube (Sold per meter)	m	EVA(d14x1t)	(Vm)	interchangable with OLD part# 002-129-15
21	002-132-11	Heat Shrink Tube (Sold per meter)	m	A4(d17x0.27t)	(Vm)	interchangable with OLD part# 002-132-11
22	140-076-17	Hex.Bolt	4	M10x30	SUS304	
23	032-161-12	Hose Coupling	1	NPT-3(GH-22L)	FC	
24	122-132-16	O-Ring	1	G-105(104.4xd3.1)	NBR	*
25	068-235-19	Handle	1	KRS2-5.5KW	SGP+SP	
26	143-085-21	Pan Screw (w/Spring Washer)	1	M4x6	SWRM	
27						
28	009-143-16	Terminal 60Hz (USA)	1	R-3.5-5S	CU	included in ITEM 1 cable assembly
29	050-363-12	Motor Bracket	1		FC	
30	122-410-11	O-Ring	1	190xd3.8	NBR	*
31	053-196-11	Motor Protector 208/230V-60Hz(USA)	1	KA314-HLXL00	(B.C)	
	053-222-17	Motor Protector 460V-60Hz (USA)	1	KA314-HRXL202	(B.C)	
	053-254-18	Motor Protector 575V-60Hz (USA)	1	KA313-GCXL103		
32	143-126-12	Pan Screw (w/Spring Washer/Plain Washer)	2	M4x12	SWRM	
33	142-197-11	Wave Washer	1	6305	SK5	
34	052-108-13	Bearing	1	6305ZZC3		
35	058-155-13	Lead Wire Protection Plate	1	d78xd180x1.6t	Bakelite	
36	055-453-15	Rotor	1Set			

PARTS LIST		AGITATOR PUMP			11/8/2019	
ITEM	PART No.	DESCRIPTION	QTY	SIZE	MATERIAL	NOTES
37	147-019-13	Impeller Key	1	7x7x32L	SUS420	
38	056-490-17	Stator 208/230V-60Hz(USA)	1Set			
	056-001-94	Stator 460V-60Hz(USA)	1Set			
		Stator 575V-60Hz(USA)	1Set			
39	121-409-14	Packing (Water Way, Upp.)	1	KRS2-5.5KW	NBR	*
40	064-443-10	Motor Frame	1		FC	
41	140-099-16	Hex.Bolt	4	M12x40	SUS304	
42	121-128-16	Packing (Water Way, Low.)	1	KRS-3.7/5.5	NBR	*
43	121-247-12	Packing	1	d12.3xd18x2t	PE	*
44	035-113-18	Oil Plug	1	M12x14	SUS304	
45	122-310-10	O-Ring	1	200xd3.5	NBR	*
46	143-042-13	Pan Screw	3	M6x10	SWRM	
47	062-116-15	Bearing Fixing Plate	1	d80xd115x3.2t	SS	
48	052-111-19	Bearing	1	6308ZZC3		
49	146-025-19	Retaining Ring	1	C40	SK5	
50	122-134-18	O-Ring	1	G-115(114.4xd3.1)	NBR	*
51	060-272-14	Bearing Housing	1		FC	
52	140-054-48	Hex.Bolt	4	M8x20	SWRM	
53	025-194-12	Mechanical Seal	1	H-30	SiC	
54	143-070-23	Pan Screw	2	M5x6	SWRM	
55	030-142-11	Oil Lifter	1	H-30(A)(T)	Resin	
56	143-070-10	Pan Screw	3	M5x6	SWRM	
57	030-151-13	Seal Stopper	1	H-30(A)(T)	SPCC	
58	020-379-18	Pump Casing	1	KRS-B3/B4	FC	
59	026-109-13	Oil Seal	1	TC-355511	NBR	
60	071-127-46	Shaft Sleeve	1	KRS-3.7/5.5KW	SUS403	
61	040-109-20	Impeller Shim		d27.5xd52x0.3t	SUS304	
62	021-571-15	Impeller (60Hz)	1	KRS2-80	HiCrFC	
	021-570-14	Impeller (50Hz) OPTION	1	KRS2-80	HiCrFC	50Hz OPTION
63	024-125-22	Connection Rod	1	KRS-80	FCMB	
64	024-120-14	Agitator	1	GPN-80	HiCrFC	
65	142-130-16	Plain Washer	1	M16	SUS304	
66	141-008-40	Hex.Nut	1	M16(H=10)	SUS304	
67	140-139-19	Hex.Bolt	1	M16x143(B=19)	SUS304	
68	120-129-14	Packing (S.Cover)		d230xd288x0.5t	PE	
69	033-115-14	Suction Plate	1	KRS-80	HiCrFC	
70	140-001-08	Hex.Bolt	3	M8x30	SUS304	interchangable with OLD part# 140-056-40
71	022-419-17	Suction Cover	1	KRS-80	FC	

PARTS LIST		AGITATOR PUMP				11/8/2019
ITEM	PART No.	DESCRIPTION	QTY	SIZE	MATERIAL	NOTES
72	142-129-12	Plain Washer	3	M12	SUS304	
73	140-096-13	Hex.Bolt	3	M12x25	SUS304	
74	142-163-18	Spring Washer	3	M8	SUS304	
75	141-005-18	Hex.Nut	3	M8	SUS304	
76	142-165-10	Spring Washer	3	M12	SUS304	
77	144-478-15	Stud Bolt	3	M12x111(25/21)	SUS403	
78	023-240-18	Strainer Stand (1st Rev)	1Set	KRS-80 (175mm)	SPC+SGP	
78	023-001-84	Strainer Stand (2nd Rev)	1Set	KRS-80 (189mm)	SGP+SS	
79	142-165-10	Spring Washer	3	M12	SUS304	
80	141-007-10	Hex.Nut	3	M12	SUS304	
	173-435-10	<b>Packing O-Ring Set</b>	1Set	(Marked by *)		
24	122-132-16	O-Ring (Hose Coupling)	1	G-105(104.4xd3.1)	NBR	*
30	122-410-11	O-Ring (M.Bracket/M.Frame)	1	190xd3.8	NBR	*
39	121-409-14	Packing (Water Way, Upp.)	1	KRS2-5.5KW	NBR	*
42	121-128-16	Packing (Water Way, Low.)	1	KRS-3.7/5.5	NBR	*
43	121-247-12	Packing (Oil Plug)	1	d12.3xd18x2t	PE	*
45	122-310-10	O-Ring (M.Frame/P.Casing)	1	200xd3.5	NBR	*
50	122-134-18	O-Ring (M.Frame/Brg.Housing)	1	G-115(114.4xd3.1)	NBR	*
		Lubricant		Turbine Oil VG32 1,850ml		
	183-010-16	Impeller Puller	1	A No.5 1"1/2"	FC	

PARTS LIST		AGITATOR PUMP		11/8/2019		
ITEM	PART No.	DESCRIPTION	QTY	SIZE	MATERIAL	NOTES

## EXPLODED VIEW

KRS2-80

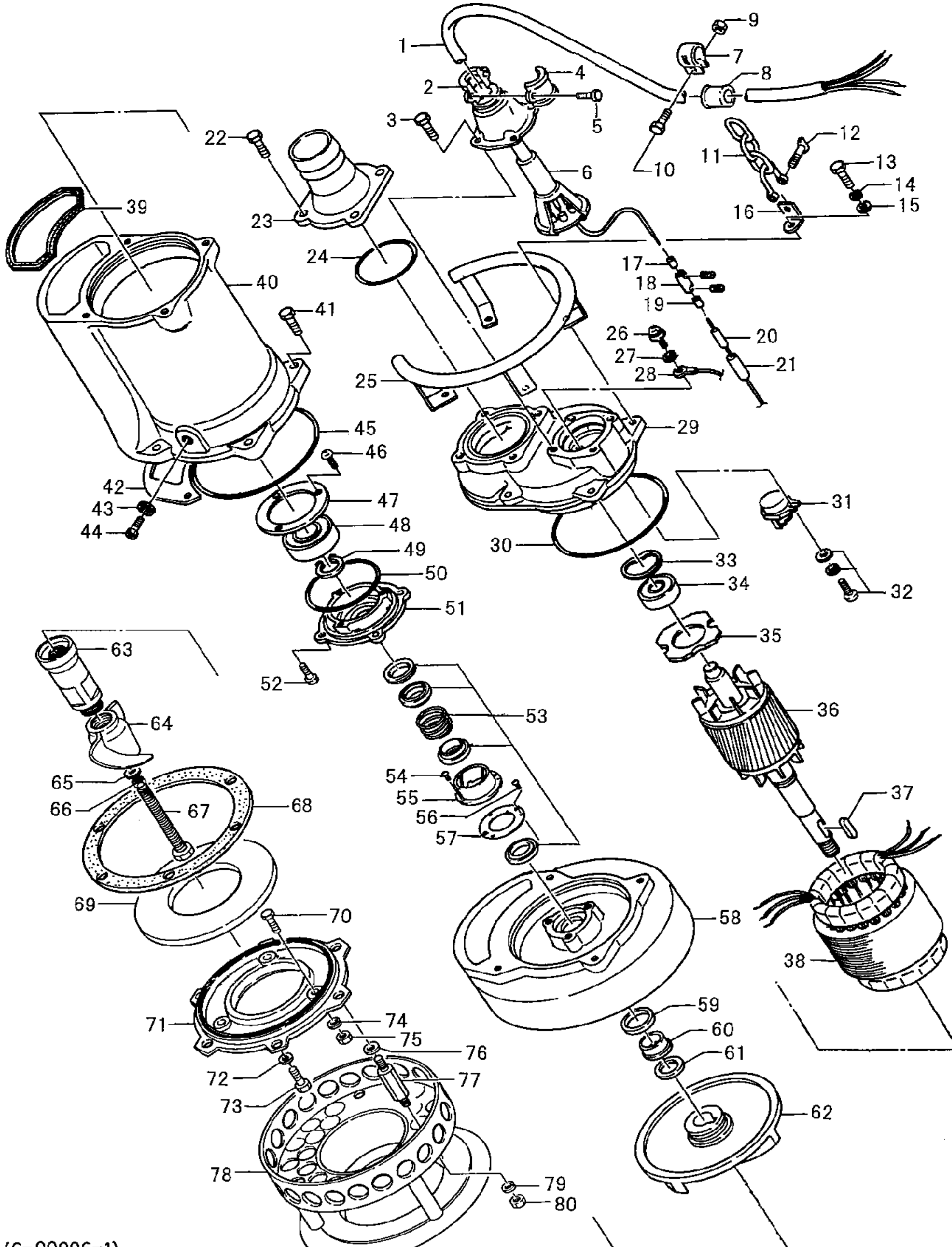

16-00006-11



MODEL **KRS2-80**

PARTS LIST		AGITATOR PUMP					11/8/2019
ITEM	PART No.	DESCRIPTION	QTY	SIZE	MATERIAL	NOTES	