

PARTS LIST		AGITATOR PUMP				10/15/2018
ITEM	PART No.	DESCRIPTION	QTY	SIZE	MATERIAL	NOTES
1	001-803-33	Cabtyre Cable Set (50')	1	VCT4Cx1.25mm2	LBT	
2	010-126-17	Cable Clip Rubber	1	HS2	NBR	
3	140-487-15	Hex.Bolt (w/Plain Washer)	1	M8x20	SUS304	
4	010-130-14	Cable Clip	1	HK2-4/15	SPC	
5	068-248-15	Handle	1	KTV2-15/22	SPC+NBR	
6	140-427-17	Hex.Bolt (w/Plain Washer)	2	M5x15	SUS304	
7	003-190-10	Gland	1		SUS316	
8	140-506-11	Hex.Bolt (w/Plain Washer)	3	M8x35	SUS304	
9	032-351-11	Hose Coupling	1	NPT-2(KTV2-15)	FC	
10	121-001-09	Packing	1	KTV2-15/22	NBR	*
11	140-432-15	Hex.Bolt (w/Spring Washer/Plain Washer)	4	M8x30	SUS304	
12	050-000-45	Motor Bracket	1		ADC	
13	122-473-12	O-Ring	1	150xd3.3	NBR	*
14	009-206-18	Earth Terminal	1Set	1.25mm2x115		
15	143-000-64	Pan Tapping Screw	1	M4x6	SUS410	
16	143-138-17	Truss Tapping Screw	2	M4x12	SWCH	
17	053-407-18	Motor Protector 208-230V-60Hz(USA)	1	KA313-GDXL103	(T)	
	053-411-15	Motor Protector 460V-60Hz(USA)	1	KA313-GQXL104	(T)	
	053-379-10	Motor Protector 575V-60Hz(USA)	1	KA313-GQVL116	(T)	
18	121-445-12	Packing (Water Way, Upp.)	1	KTV2-15/22	NBR	*
19	058-167-18	Protection Plate	1	KTV2-15/22	Bakelite	
20	122-293-16	O-Ring	1	47xd3.1	NBR	*
21	142-195-19	Wave Washer	1	6204/6303(d47x,0.3t)	SK5	
22	052-103-18	Bearing	1	6204ZZC3		
23		Stator 208-230V-60Hz (USA)	1Set			
		Stator 460V-60Hz (USA)	1Set			
		Stator 575V-60Hz (USA)	1Set			
24	145-028-19	Stator Set Pin	1	d6x32	S45C	
25	055-662-19	Rotor	1Set	w/Bearing		
26	147-128-16	Impeller Key	1	5x5x18.5L	SUS403	
27	061-161-12	Bearing Collar	1	d25.1xd36x1.6t	SPC	
28	052-108-13	Bearing	1	6305ZZC3		
29	064-000-84	Motor Frame	1		ADC	
30	121-246-11	Packing	1	d10.3xd16x2t	PE	*
31	035-125-13	Oil Plug	1	M10x20(B=13)	SUS304	
32	025-243-17	Mechanical Seal	1	H-20T	SIC	
33	143-070-23	Pan Screw	2	M5x6	SWRM	
34	030-144-13	Oil Lifter	1	H-20(A)(T)	Resin	

PARTS LIST		AGITATOR PUMP				10/15/2018
ITEM	PART No.	DESCRIPTION	QTY	SIZE	MATERIAL	NOTES
35	143-070-10	Pan Screw	2	M5x6	SWRM	
36	030-155-17	Seal Stopper	1	H-20(KTV2)	SPCC	
37	122-134-18	O-Ring	1	G-115(114.4xd3.1)	NBR	*
38	121-001-04	Packing (Water Way, Low.)	1	KTV2-15/22	SBR	*
39	029-000-77	Oil Casing	1	KTV2-15/22	ADC	
40	140-270-13	Hex.Socket Cap Bolt	4	M8x30	SUS304	
41	031-000-08	Wear Ring	1	KTV2-15/22	BR+NR	
42	058-000-25	Protection Plate	1	d41xd70x3t	SUS304	
43	143-166-14	Flat Screw	2	M4x8	SUS304	
44	122-443-13	V-Ring	1	VR-20	NBR	
45	071-297-19	Shaft Sleeve	1	d16xd20x10l	SUS304	
46	021-F79-13	Impeller (60Hz)	1	KTV2-50	HiCrFC	
	021-F78-12	Impeller (50Hz) OPTION	1	KTV2-50	HiCrFC	50Hz OPTION
47	142-129-25	Plain Washer	1	M12	SPC	
48	142-165-10	Spring Washer	1	M12	SUS304	
49	141-007-49	Hex.Nut	1	M12(H=7)	SUS304	
50	024-153-16	Aqitator	1	KTV2-50	FCD	
51	020B1918	Pump Casing	1	KTV2-15/22	BR+NR	
52	127-249-12	Fixing Plate	1	KTV2-15/22	SPCC	
53	023-433-10	Strainer Stand	1	KTV2-50	SPCC+SGP	
54	140-000-53	Hex.Bolt (w/Plain Washer)	4	M8x85(22L)	SUS304	
	173-472-19	<b>Packing O-Ring Set</b>	1Set	(Marked by *)		
10	121-001-09	Packing (Hose Coupling)	1	KTV2-15/22	NBR	*
13	122-473-12	O-Ring (M.Bracket/M.Frame)	1	150xd3.3	NBR	*
18	121-445-12	Packing (Water Way, Upp.)	1	KTV2-15/22	NBR	*
20	122-293-16	O-Ring (Upp. Bearing)	1	47xd3.1	NBR	*
30	121-246-11	Packing (Oil Plug)	1	d10.3xd16x2t	PE	*
37	122-134-18	O-Ring (M.Frame/O.Casing)	1	G-115(114.4xd3.1)	NBR	*
38	121-001-04	Packing (Water Way, Low.)	1	KTV2-15/22	SBR	*
		Lubricant		Turbine Oil VG32 270ml		

PARTS LIST		AGITATOR PUMP			10/15/2018	
ITEM	PART No.	DESCRIPTION	QTY	SIZE	MATERIAL	NOTES

## EXPLODED VIEW KTV2-50

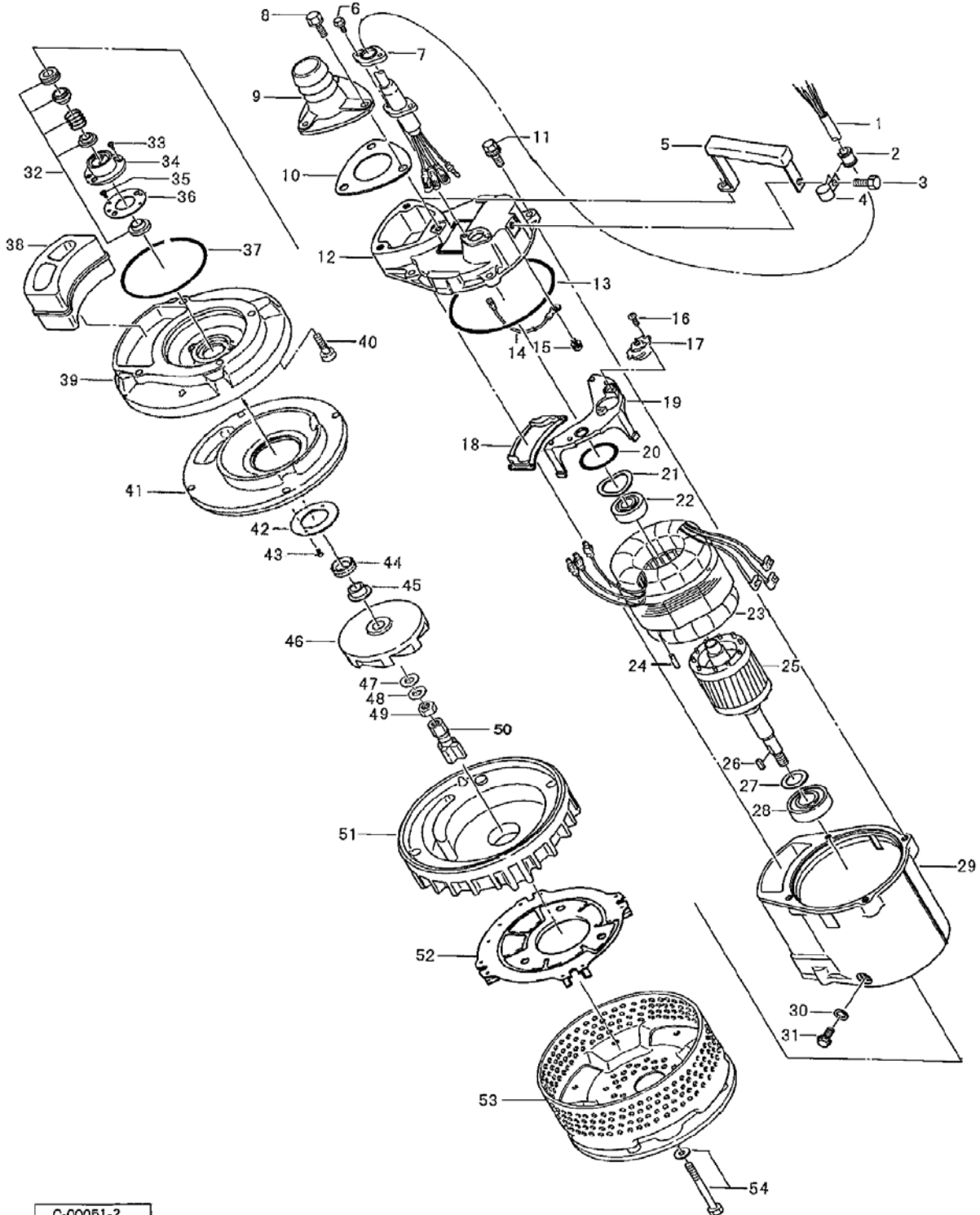

C-00051-2