

Model 230S

230 GPM

Performance Curves

FLOW RANGE: 160 -320 GPM

OUTLET SIZE: 3" NPT

NOMINAL DIA. 6"

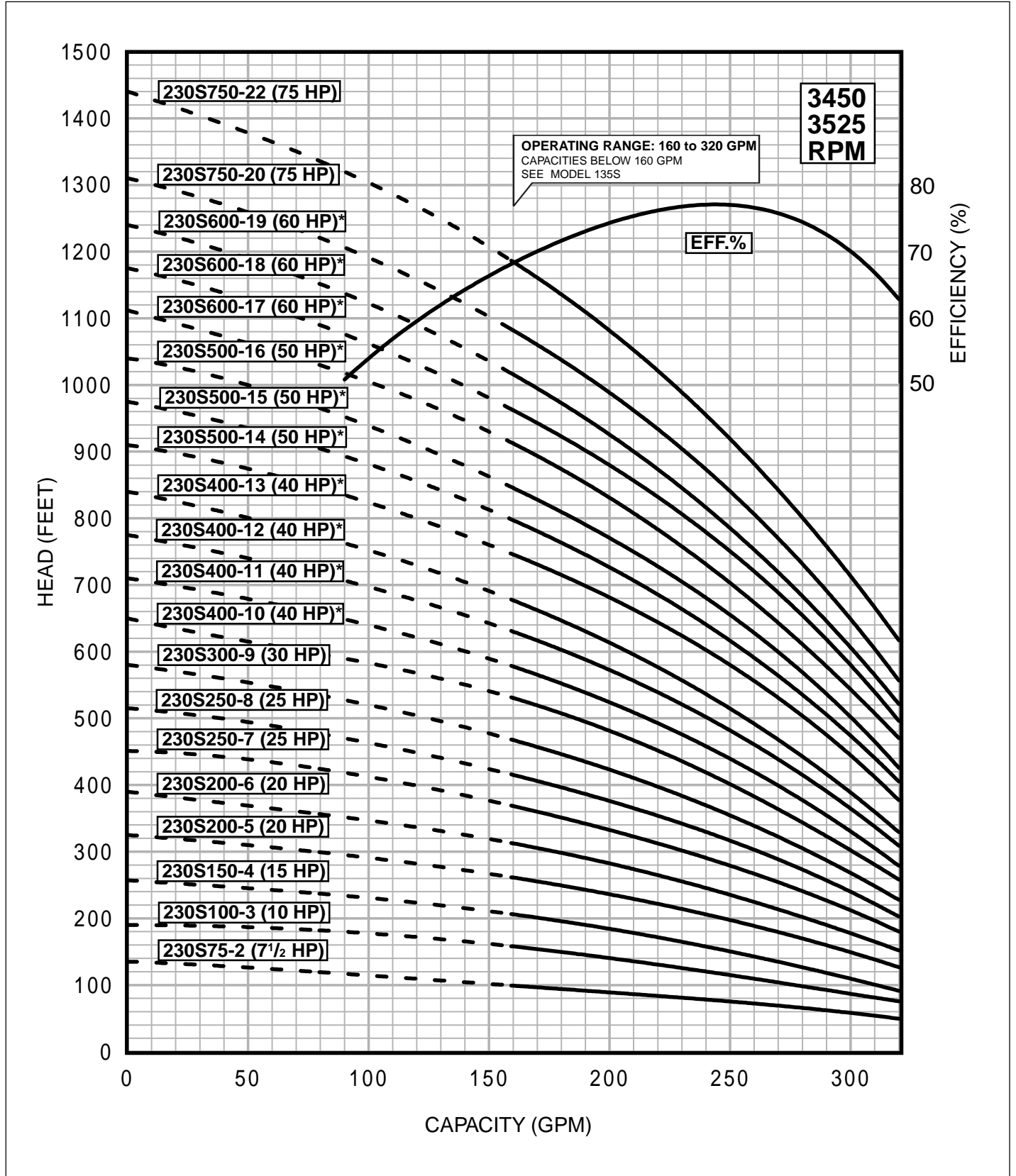

SPECIFICATIONS SUBJECT TO CHANGE WITHOUT NOTICE.

4" MOTOR STANDARD, 7.5 HP/3450 RPM
6" MOTOR STANDARD, 7.5-40 HP/3450 RPM.
8" MOTOR STANDARD, 50-75 HP/3525 RPM.

* Alternate motor sizes available.

Performance conforms to ISO 2548 Annex B
@ 8 ft. min. submergence.

DIMENSIONS AND WEIGHTS

MODEL NO.	FIG.	HP	MOTOR SIZE	DISCH. SIZE	DIMENSIONS IN INCHES					APPROX. SHIP WT.
					A	B	C	D	E	
230S75-2	A	7.5	4"	3" NPT	48.5	29.6	18.9	3.8	5.6	88
230S100-3	A	10	4"	3" NPT	67.8	43.9	23.9	3.8	5.6	146
230S75-2	A	7.5	6"	3" NPT	43.0	24.2	18.9	5.4	5.7	124
230S100-3	A	10	6"	3" NPT	49.3	25.4	23.9	5.4	5.7	140
230S150-4	A	15	6"	3" NPT	56.4	28.0	28.4	5.4	5.7	161
230S200-5	A	20	6"	3" NPT	63.4	30.6	32.8	5.4	5.7	167
230S200-6	A	20	6"	3" NPT	67.8	30.6	37.3	5.4	5.7	186
230S250-7	A	25	6"	3" NPT	74.9	33.1	41.7	5.4	5.7	202
230S250-8	A	25	6"	3" NPT	79.3	33.1	46.2	5.4	5.7	209
230S300-9	A	30	6"	3" NPT	86.3	35.7	50.6	5.4	5.7	228
230S400-10*	A	40	6"	3" NPT	95.4	40.3	55.1	5.4	5.7	234
230S400-11*	A	40	6"	3" NPT	100.3	40.81	59.5	5.4	5.7	273
230S400-12*	A	40	6"	3" NPT	104.8	40.81	64.0	5.4	5.7	279
230S400-13*	A	40	6"	3" NPT	109.2	40.81	68.4	5.4	5.7	284
230S500-14*	A	50	6"	3" NPT	130.7	57.83	72.9	5.4	5.7	388
230S500-15*	A	50	6"	3" NPT	135.2	57.83	77.3	5.4	5.7	393
230S500-16*	A	50	6"	3" NPT	139.6	57.83	81.8	5.4	5.7	399
230S600-17*	A	60	6"	3" NPT	151.2	63.83	87.4	5.4	5.7	438
230S600-18*	A	60	6"	3" NPT	155.6	63.83	91.8	5.4	5.7	445
230S600-19*	A	60	6"	3" NPT	160.1	63.83	96.3	5.4	5.7	449
230S600-17	A	60	8"	3" NPT	129.2	41.79	87.4	7.5	7.6	544
230S600-18	A	60	8"	3" NPT	133.6	41.79	91.8	7.5	7.6	551
230S600-19	A	60	8"	3" NPT	138.0	41.79	96.3	7.5	7.6	555
230S750-20**	B	75	8"	4" M-NPT	154.7	47.41	107.3	7.5	7.6	634
230S750-22**	B	75	8"	4" M-NPT	163.6	47.41	116.2	7.5	7.6	681

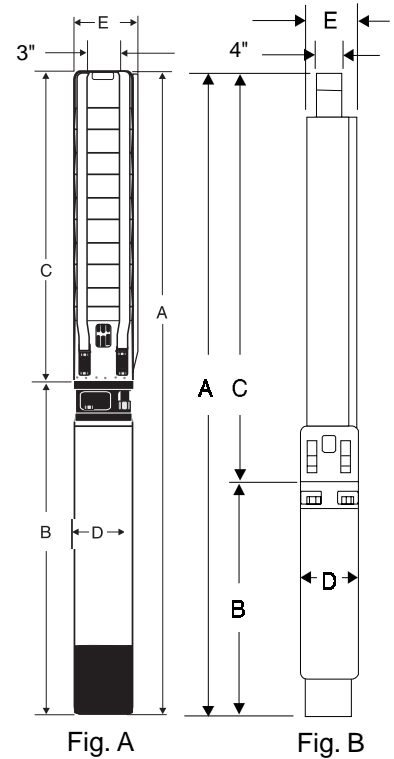

NOTES: All models suitable for use in 6" wells, unless equipped with 8" motor.

Weights include pump end with motor in lbs.

* Alternate motor sizes available.

** Built into sleeve, 4" M-NPT, 8" motor required.

MATERIALS OF CONSTRUCTION

COMPONENT	CYLINDRICAL SHAFT (2-18 Stgs.)
Check Valve Housing	304 Stainless Steel
Check Valve	304 Stainless Steel
Diffuser Chamber	304 Stainless Steel
Split Cone Nut	304 Stainless Steel
Split Cone	304 Stainless Steel
Impeller	304 Stainless Steel
Suction Interconnector	304 Stainless Steel
Inlet Screen	304 Stainless Steel
Straps	304 Stainless Steel
Cable Guard	304 Stainless Steel
Coupling	329/416 Stainless Steel
Coupling Key	302/304 Stainless Steel
Pump Shaft	431 Stainless Steel
Intermediate Bearings	NBR
Impeller Seal Ring	NBR/304 Stainless Steel
Check Valve Seat	NBR/316 Stainless Steel
Top/Lower Bearing	NBR/316 Stainless Steel
8" Motor Adaptor Plate	304 Stainless Steel
Upthrust Washer	Carbon/Graphite HY22
Upthrust stop ring	316 S.S./Tungsten Carbide
Sleeve*	304 Stainless Steel
Sleeve Flange*	304 Stainless Steel

NOTES: Specifications subject to change without notice.

* Required for 20-22 stage only.

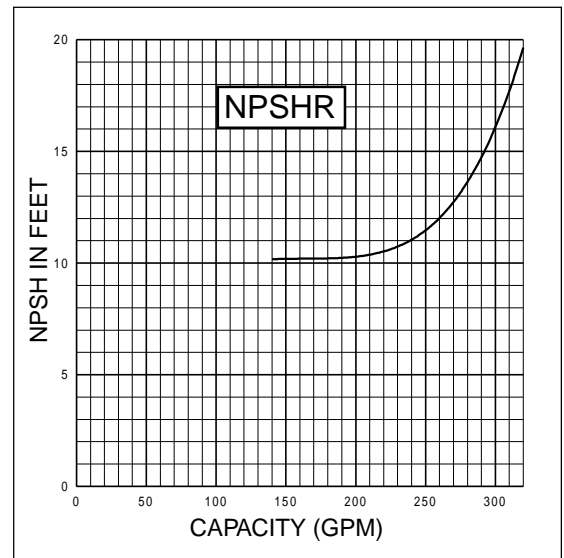

GRUNDFOS PUMPS CORPORATION • 3131 N. Business Park Avenue • Fresno, CA • 93727

Customer Service Centers: Allentown, PA • Fresno, CA

Phone (800) 333-1366 • FAX (800) 333-1363

Canada: Oakville, Ontario • Mexico: Apodaca, N.L.

LSP-TL-1230 Rev.7/98
PRINTED IN USA