

## 22 SQ, SQE

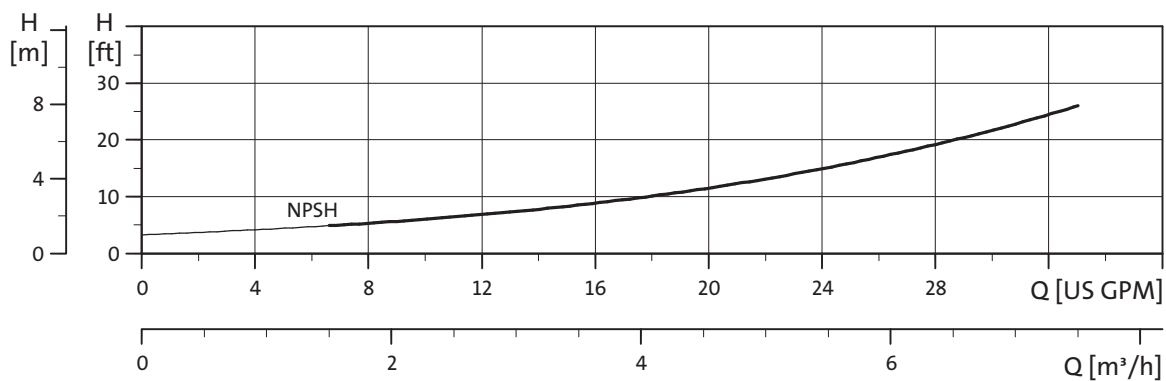

TIM04 7466 2010

### 22 SQE-NE

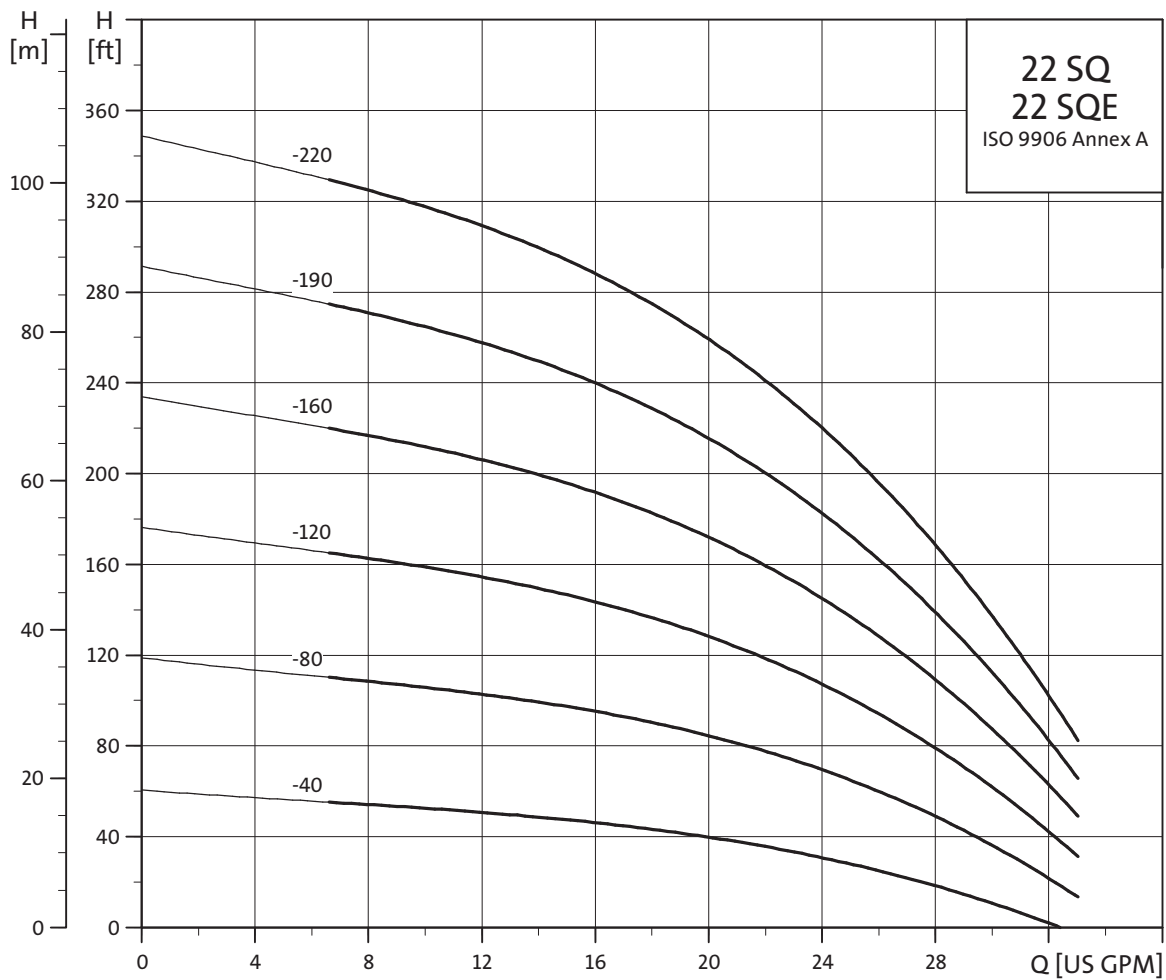
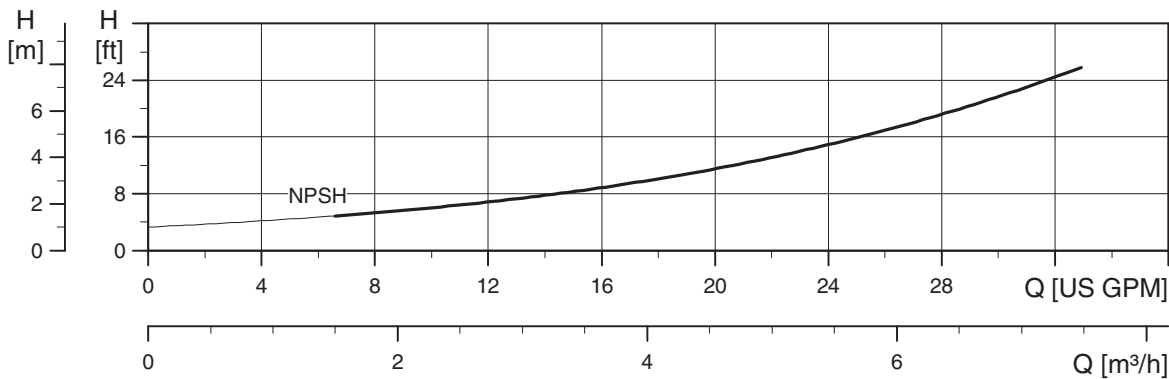
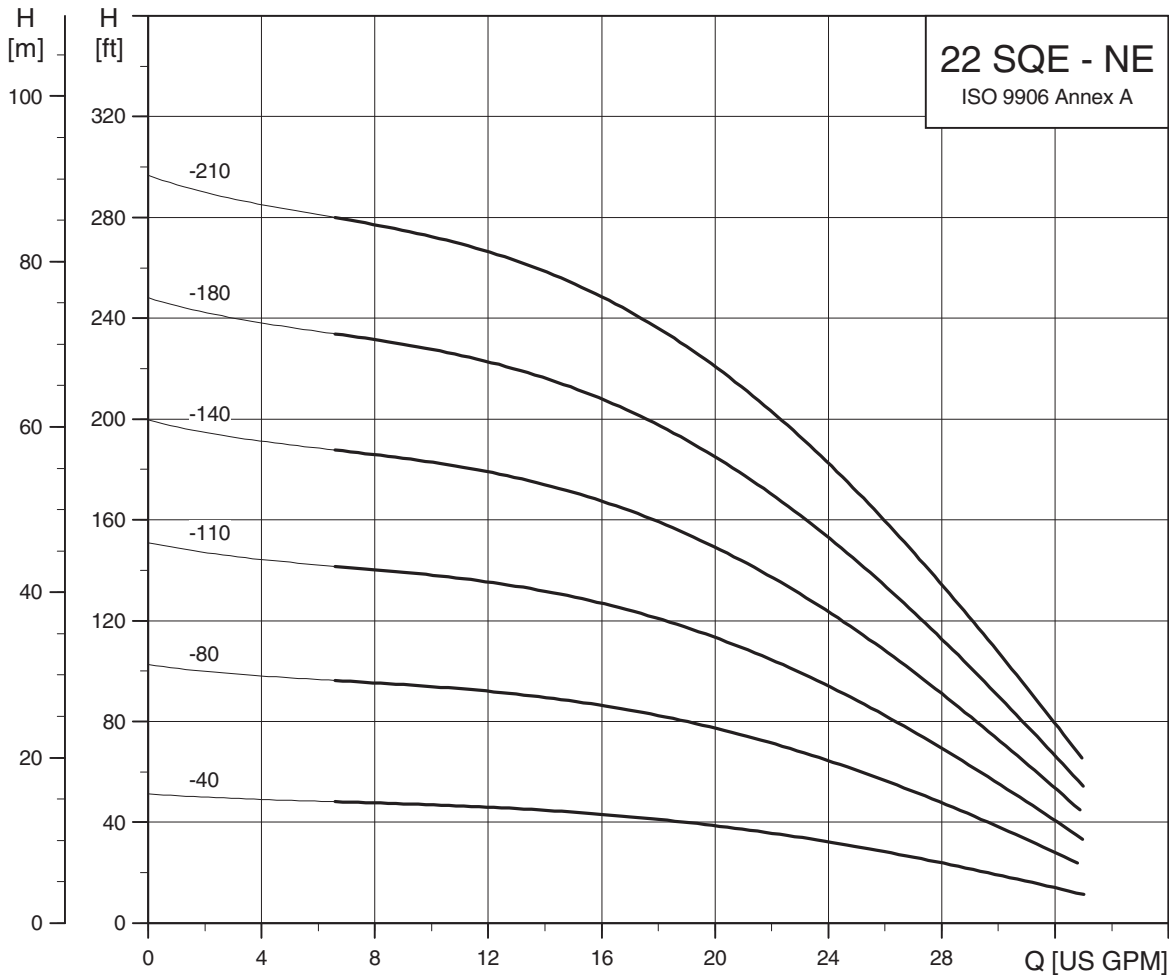

TIM04 7469 2010

## Dimensions and weights

### SQ, SQE

Model	Hp	Motor size	Discharge size	Dimensions in inches					Approx. ship. wt.
				A	B	C	D	E	
22SQ/SQE05-40	1/2	3"	1 1/2" NPT	30.4	19.8	10.6	2.6	2.9	12
22SQ/SQE05-80	1/2	3"	1 1/2" NPT	30.4	19.8	10.6	2.6	2.9	12
22SQ/SQE07-120	3/4	3"	1 1/2" NPT	31.5	19.8	11.6	2.6	2.9	13
22SQ/SQE10-160	1	3"	1 1/2" NPT	33.6	19.8	13.7	2.6	2.9	13
22SQ/SQE10-190	1	3"	1 1/2" NPT	38.2	21.3	16.9	2.6	2.9	16
22SQ/SQE15-220	1 1/2	3"	1 1/2" NPT	38.2	21.3	16.9	2.6	2.9	16

## Material specification

Pump						
Pos.	Component	Material	DIN W-Nr. SQ/SQE	AISI	DIN W-Nr. SQE-NE	AISI
1	Valve casing	Polyamide	1.4301	304	1.4401	316
1a	Discharge chamber	Stainless steel				
1d	O-ring	NBR rubber				
2	Valve cup	Polyamide				
3	Valve seat	NBR rubber				
4a	Empty chamber	Polyamide				
6	Top bearing	NBR rubber				
7	Neck ring	TPU / PBT				
7a	Lock ring	Stainless spring steel	1.4301	310	1.4401	316
7b	Neck ring retainer	Polyamide				
9b	Chamber top	Polyamide				
9c	Chamber bottom	Polyamide				
13	Impeller with tungsten carbide bearing	Polyamide				
14	Suction inter-connector	Polyamide				
14a	Ring	Stainless steel	1.4301	304	1.4401	316
16	Shaft with coupling	Stainless steel Sintered steel	1.4301	304	1.4401	316
18	Cable guard	Stainless steel	1.4301	304	1.4401	316
18a	Screws for cable guard	Stainless steel	1.4301	316	1.4401	316
18b						
30	Cone for pressure equalization	Polyamide				
32	Guide vanes	Polyamide				
39	Spring	Stainless spring steel	1.4406	316LN	1.4406	316LN
55	Pump sleeve	Stainless steel	1.4301	304	1.4401	316
64	Priming screw	Polyamide				
70	Valve guide	Polyamide				
86	Lip seal ring	NBR rubber				
87	Cone for pressure equalization complete	Polyamide / NBR rubber				

Motor						
Pos.	Component	Material	DIN W-Nr. SQ-SQE	AISI	DIN W-Nr. SQE-NE	AISI
201	Stator	Stainless steel	1.4301	304	1.4401	316
202	Rotor	Stainless steel	1.4301	304	1.4401	316
202a	Stop ring	PP				
202b	Filter	Polyester				
203	Thrust bearing	Carbon				
205	Radial bearing	Ceramic tungsten carbide				
220	Motor cable with plug	EPR				
222a	Filling plug	MS 3: NBR MSE 3: FKM				
224	O-ring	FKM				
225	Top cover	PPS				
232	Shaft seal	MS 3: NBR MSE 3: FKM				
	Motor liquid	SML-2				

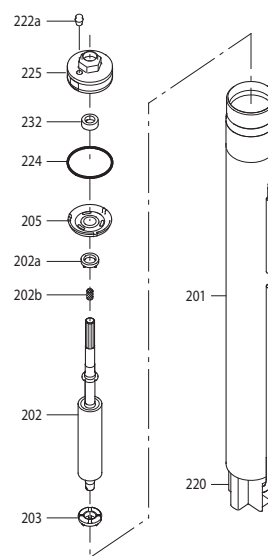
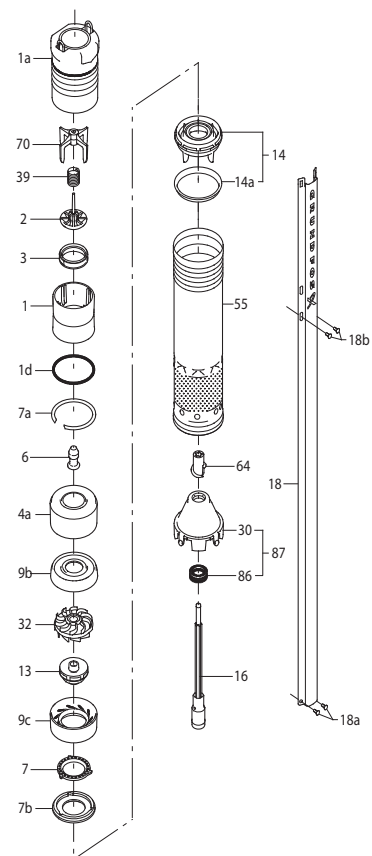

TM01 2745 2010