

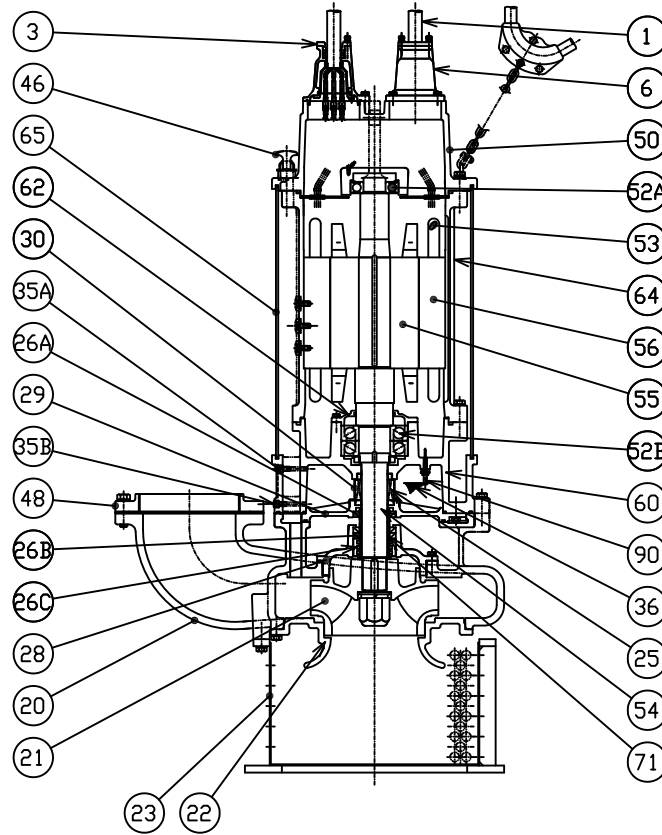

**GSZ-4 SERIES**  
HIGH VOLUME - DEWATERING PUMP

**SECTIONAL VIEW**

**GSZ2-75-4L**



PART#	DESCRIPTION	MAIN MATERIAL / NOTE	RELATED ASTM,AISI CODE	RELATED EN CODE	QTY
1	Power Cable	Chloroprene Sheath AWG 2/3, 6/1, 14/3 -50ft			1
	Power Cable	Chloroprene Sheath AWG 2/3 -50ft			1
3	Gland	Cast Iron	A48M Class30B	EN 1561 GJL-200	2
6	Stuffing Box	Cast Iron	A48M Class30B	EN 1561 GJL-200	2
20	Pump Casing	Cast Iron	A48M Class30B	EN 1561 GJL-200	1
21	Impeller	High Chrome Cast Iron	A532 Class III TypeA	DIN 1695 G-X260Cr27	1
22	Suction Cover	Cast Iron	A48M Class30B	EN 1561 GJL-200	1
23	Suction Strainer	Steel	A283 Grade D	EN 10025 S275	1
25	Mechanical Seal	Silicon Carbide / H-70			1
26A	Oil Seal	NBR / TC-8011515			1
26B	Oil Seal	NBR / TC-8011515			2
26C	Labyrinth Ring	Stainless Steel	S 40300	1.4000	1
28	Seal Housing	NBR / TC709513	A48M Class30B	EN 1561 GJL-200	1
29	Oil Casing	Cast Iron	A48M Class30B	EN 1561 GJL-200	1
30	Oil Lifter	Steel (Cold Rolled)	A109 / A1008	EN 10130	1
35A	Oil Plug	Stainless Steel	S 30400	1.4301	2
35B	Oil Plug	Stainless Steel	S 30401	2.4301	1
36	Lubricant	Turbine Oil ISO VG32 or SAE 10W-20			
46	Air Release Valve	Steel (Cold Rolled)	A109 / A1008	EN 10130	1
48	Companion Flange	Cast Iron / NPT 10" JIS10K	A48M Class30B	EN 1561 GJL-200	1
50	Motor Bracket	Cast Iron	A48M Class30B	EN 1561 GJL-200	1
52A	Upper Bearing	#6312ZZC3			1
52B	Lower Bearing	#7317BDB			1
53	Motor Protector				3
54	Shaft	Stainless Steel	S 42000	1.4028	1
55	Rotor				1
56	Stator				1
60	Bearing Housing	Cast Iron	A48M Class30B	EN 1561 GJL-200	1
62	Bearing Cover	Cast Iron	A48M Class30B	EN 1561 GJL-200	1
64	Motor Housing	Cast Iron	A48M Class30B	EN 1561 GJL-200	1
65	Outer Cover	Steel	A283 Grade D	EN 10025 S275	1
71	Shaft Sleeve	Stainless Steel	S 40300	1.4000	1
90	Leak Sensor (Electrode)	Stainless Steel	S 30300	1.4305	1