



TSURUMI PUMP®

BUILT FOR WORK®

THREE PHASE DEWATERING PUMPS



Rugged Tsurumi pumps are loaded top to bottom with features to withstand your toughest dewatering applications.

- 1 Motor Protector:**
Thermal protector integral to the motor, directly cuts the motor circuit if excessive heat builds up.
- 2 Anti-Wicking Block:**
Prevents water incursion due to capillary wicking should the power cable be damaged or the end submerged.
- 3 Double Inside Mechanical Seal with Silicon Carbide Faces:**
Provides the longest operational life of any available seal.
- 4 Oil Lifter:**
Lubrication of the seal faces down to 1/3 of normal oil level and greatly extends the seal life - uses no additional power.
- 5 Ball Bearings:**
Permanently lubricated, double-shielded, single row deep groove, high temperature C3 Ball bearings, Rated B-10 = 60,000 Hours.
- 6 Lip Seal Protector:**
Protects mechanical seal from abrasive particles.
- 7 High Chrome Iron / Ductile Iron Impeller:**
Resists wear by abrasive particles.
- 8 Field Adjustable / Replaceable Suction Cover:**
Resists wear by abrasive particles, and is easily adjusted to maintain pump performance.

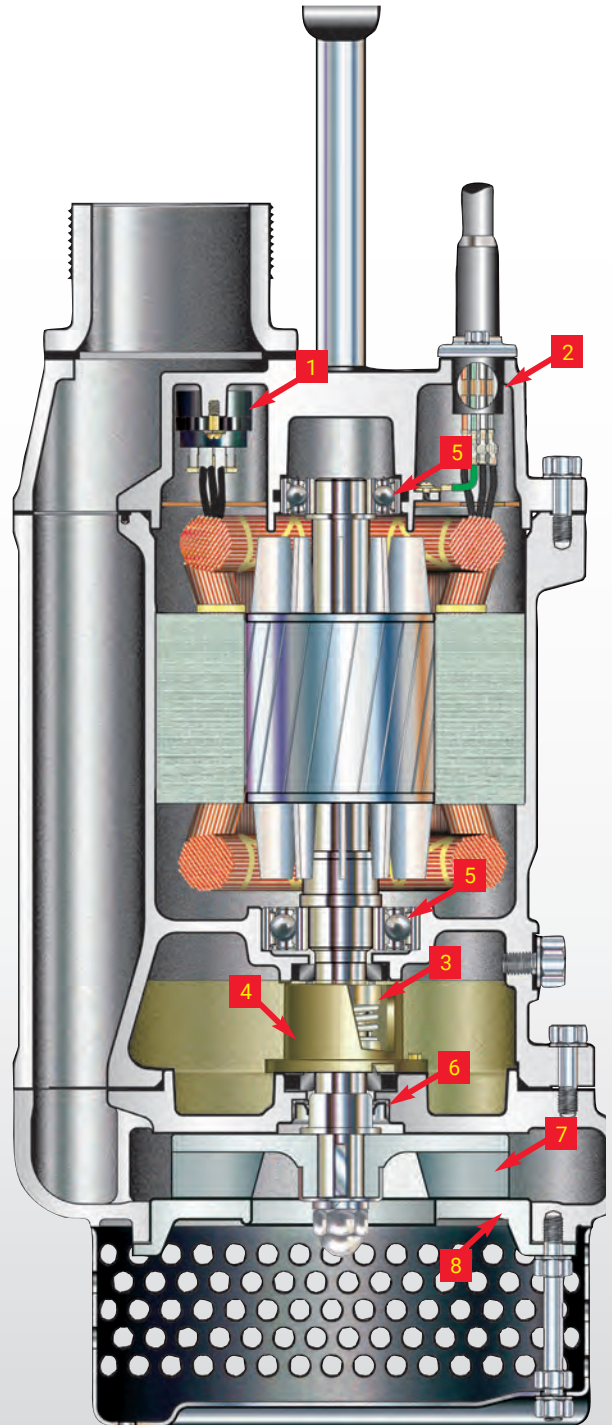

The cutaway view above is a KTZ series pump. This pump illustrates the common design features used in Tsurumi dewatering pumps. Other series may differ in shape and structure.



Three Phase Dewatering Pump Lineup

KTZ(E) Series



High head and high volume dewatering. Semi-open High Chrome Impeller.

Easy conversion between high head and high volume models in each motor size.

KTZE pumps with built-in electrode for automatic operation without a control panel.

Discharge Sizes: 2, 3, 4 and 6 inch

HP: 2, 3, 5, 7.5, 10, & 15

LH Series



Medium to high volume at high heads.

Closed High Chrome Impeller.

Easy conversion between high head and high volume models in each motor size.

Discharge Sizes: 4, 6, and 8 inch

HP: 4, 20, 30, 35, 40, 50, 60, 75, 100, 120, & 150

LHW Series



Extra high head pumping.

Dual staged, Closed High Chrome Impeller.

Pressure relief ports protect mechanical seal from excessive pressure and water hammer.

Discharge Sizes: 2, 3, and 4 inch

HP: 4, 7.5, 15, 30, 40 & 150

KTV(E) Series



Portable job-site dewatering.

Semi-vortex Urethane Rubber or Ductile Iron Impeller.

KTVE pumps with built-in electrode for automatic operation without a control panel.

Discharge Sizes: 2 and 3 inch

HP: 1, 2, 3, 5, & 7.5

KRS Series



High volume dewatering.

Semi-open Ductile Iron and High Chrome Impeller.

1800RPM and 1200 RPM motors reduce impeller wear.

Discharge Sizes: 3, 4, 6, 8, 10, 12, and 14 inch

HP: 3, 5, 7.5, 10, 15, 20, 25, 30, 40, & 50

GSZ Series



High volume dewatering pumping.

Closed High Chrome and Stainless Steel Impeller.

1800 RPM and 1200 RPM motors reduce impeller wear.

Discharge Sizes: 6, 8, and 10 inch

HP: 30, 50, 60, 75, 100 & 200

Agitator Pumps



Heavy duty slurry pumping.

Abrasive resistant.

Single phase and three phase solutions.

Discharge Sizes: 2 - 10 inch

HP: 1/2 - 100

SFQ Series



Corrosive liquid dewatering.

Semi-open Stainless Steel Impeller.

All parts in contact with the liquid are 316 Stainless Steel.

All elastomers are Viton.

Discharge Sizes: 2, 3 and 4 inch

HP: 1, 2, 5, 7.5, 10 & 15

SQ Series



Portable corrosive liquid dewatering.

Semi-open Stainless Steel Impeller.

All parts in contact with the liquid are 304 Stainless Steel.

Discharge Sizes: 2 inch

HP: 1/2 & 1

LB / LBT Series



For well dewatering: Fits in 8" casing.

Semi-Vortex Impeller.

Allows for jobsite dewatering utilizing smaller generators and smaller well casings.

Discharge Sizes: 2 and 3 inch

HP: 1/2, 1 & 2

KTZ(E) SERIES | High volume, extra durable pump available in variety of sizes



Material

- Impeller: High Chrome Iron
- Casing: Cast Iron
- Mechanical Seal: Silicon Carbide
- Motor Frame: Cast Iron
- Shaft: 420 Stainless Steel
- Fasteners: 304 Stainless Steel
- Cable: PVC, Chloroprene Sheath

Features

- Easily converted between high pressure and high volume configurations
- High Pressure Rated Mechanical Seals
- Rugged Iron Construction
- Anti-Wicking Cable Entrance
- Dual Silicon Carbide Mechanical Seals
- Oil Lifter
- Internal Thermal Motor Protection
- Automatic Operation on KTZE Series

Group Performance Curves: KTZE 2 - 5 HP

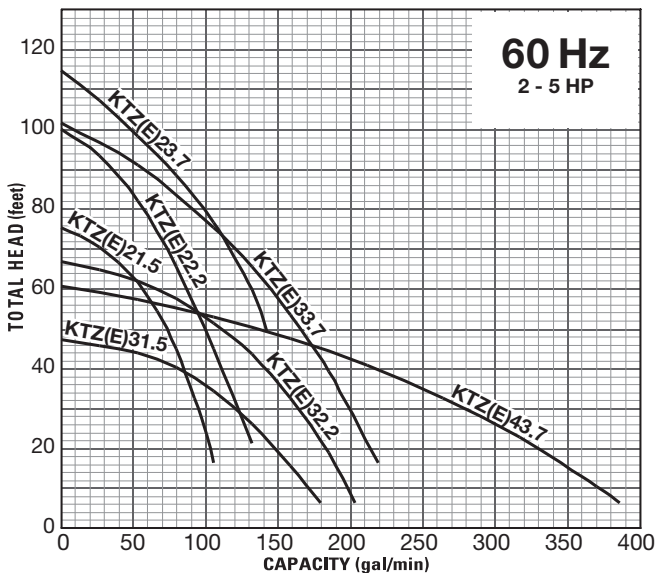

Group Performance Curves: KTZ 7.5 - 15 HP

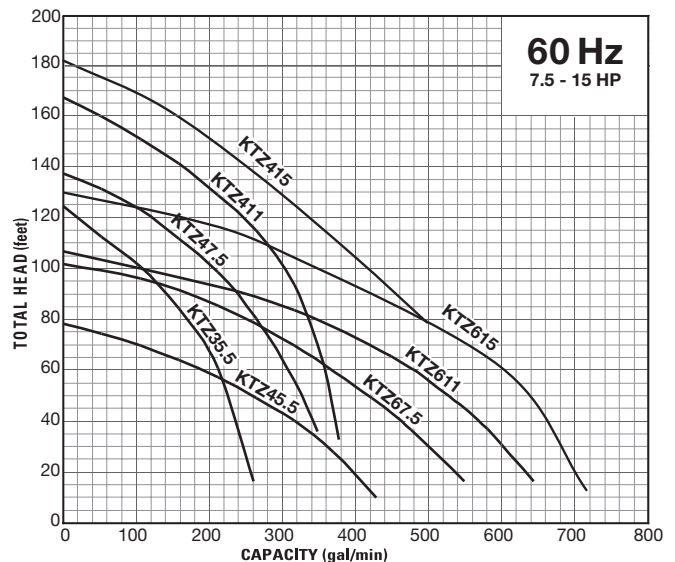

* KTZ415 and KTZ615 not available in Canada

The **KTZ series** is designed with high-chrome impellers to withstand the most demanding conditions, including highly abrasive liquids found in construction, aggregate and mining applications. Versatility is increased as each pump model has the capability of being easily converted between high head and high volume performance with a simple change of impeller and wear plate. Dual high-pressure silicon carbide mechanical seals are isolated in the oil chamber to protect the seal faces from abrasion and corrosion. Tsurumi incorporates Pressure Relief Ports on the 10HP and 15HP models, exposing the mechanical seal only to the pressure developed by the sump submergence level. This has virtually eliminated the premature wear and failure of mechanical seals in higher pressure applications.

The **KTZE series** offers the same features as the KTZ series with the added benefit of an integrally mounted electrode probe for turning the pump on and off automatically. Unnecessary dry-run is prevented to save energy and reduce wear without the need for auto control panels and cumbersome float assemblies. The pump installs and handles like a standard pump yet operates automatically by simply connecting to a manual control panel.

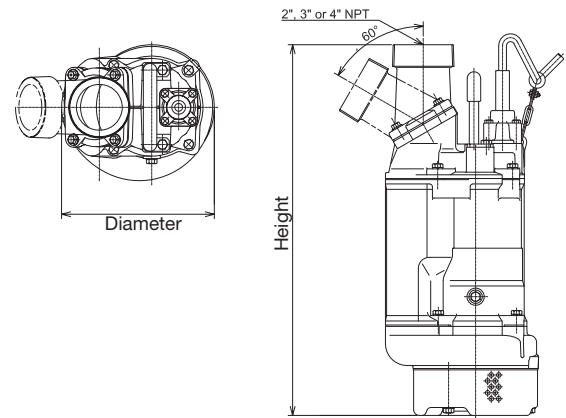

MODEL	MOTOR SPECIFICATIONS					RPM	Discharge Size (inch)	DIMENSION		Max. Solids Dia. (inch)	Continuous Running Water Level (in.)	Pump Weight (lbs.)
	Output (HP)	Rated Current (A)			Diameter			Height				
		208V	230V	460V	575V							
KTZ21.5	2	6.2	6.0	3.1	2.3	3600	2	9 1/4	25 1/2	0.334	4 3/4	77
KTZ31.5	2	6.2	6.0	3.1	2.3	3600	3	9 1/4	25 1/2	0.334	4 3/4	75
KTZ22.2	3	9.4	9.0	4.5	3.5	3600	2	9 1/4	26 5/16	0.334	4 3/4	79
KTZ32.2	3	9.4	9.0	4.5	3.5	3600	3	9 1/4	26 5/16	0.334	4 3/4	77
KTZ23.7	5	15	13.6	6.8	5.3	3600	2	11 1/8	26 1/4	0.334	5 7/8	137
KTZ33.7	5	15	13.6	6.8	5.3	3600	3	11 1/8	26 5/8	0.334	5 7/8	137
KTZ43.7	5	15	13.6	6.8	5.3	3600	4	11 1/8	27 1/16	0.334	5 7/8	137
KTZ35.5	7.5	21	19.7	10	7.9	3600	3	12 1/16	28 3/8	0.334	5 7/8	167
KTZ45.5	7.5	21	19.7	10	7.9	3600	4	12 1/16	28 3/4	0.334	5 7/8	170
KTZ47.5	10	29.8	27.3	13.3	10.4	3600	4	13	31 7/8	0.472	7 1/2	229
KTZ67.5	10	29.8	27.3	13.3	10.4	3600	4 (6)*	13 (14 7/16)*	31 7/8	0.787	7 1/2	222 (227)*
KTZ411	15	39.8	37.4	18.6	14.9	3600	4	14 3/4	32 15/16	0.472	7 1/2	293
KTZ611	15	39.8	37.4	18.6	14.9	3600	4 (6)*	14 3/4	32 15/16 (33 11/16)*	0.787	7 1/2	293

(*) 6inch is optional

MODEL	MOTOR SPECIFICATIONS					RPM	Discharge Size (inch)	DIMENSION		Max. Solids Dia. (inch)	Pump Starting Water Level (in.)	Pump Weight (lbs.)
	Output (HP)	Rated Current (A)			Diameter			Height				
		208V	220V	460V	575V							
KTZE21.5	2	6.2	6.0	3.1	2.3	3600	2	9 1/4	28 11/16	0.334	13 5/8*	88
KTZE31.5	2	6.2	6.0	3.1	2.3	3600	3	9 1/4	28 11/16	0.334	13 5/8*	86
KTZE22.2	3	9.4	9.0	4.5	3.5	3600	2	9 1/4	29 7/16	0.334	14*	93
KTZE32.2	3	9.4	9.0	4.5	3.5	3600	3	9 1/4	29 7/16	0.334	14*	90
KTZE23.7	5	15	13.8	6.8	5.3	3600	2	11 1/8	29 7/16	0.334	17 1/8*	163
KTZE33.7	5	15	13.8	6.8	5.3	3600	3	11 1/8	29 13/16	0.334	17 1/8*	163
KTZE43.7	5	15	13.8	6.8	5.3	3600	4	11 1/8	30 3/16	0.334	17 1/8*	163

LH / LHW SERIES | Extreme high pressure pumping at high volumes



LH6110



LH4110W



LH33.0

Material

- Impeller: High Chrome Iron
- Casing: Ductile Cast Iron
- Mechanical Seal: Silicon Carbide
- Motor Frame: Cast Iron
- Shaft: 420 Stainless Steel
- Fasteners: 304 Stainless Steel
- Cable: Chloroprene Sheath

Features

- High Pressure Capability
- High Pressure Rated Mechanical Seals
- Seal Pressure Relief Ports
- Rugged Iron Construction
- Anti-Wicking Cable Entrance
- Dual Silicon Carbide Mechanical Seals
- Oil Lifter
- Internal Thermal Motor Protection

Group Performance Curves: LH / LHW Series Pumps

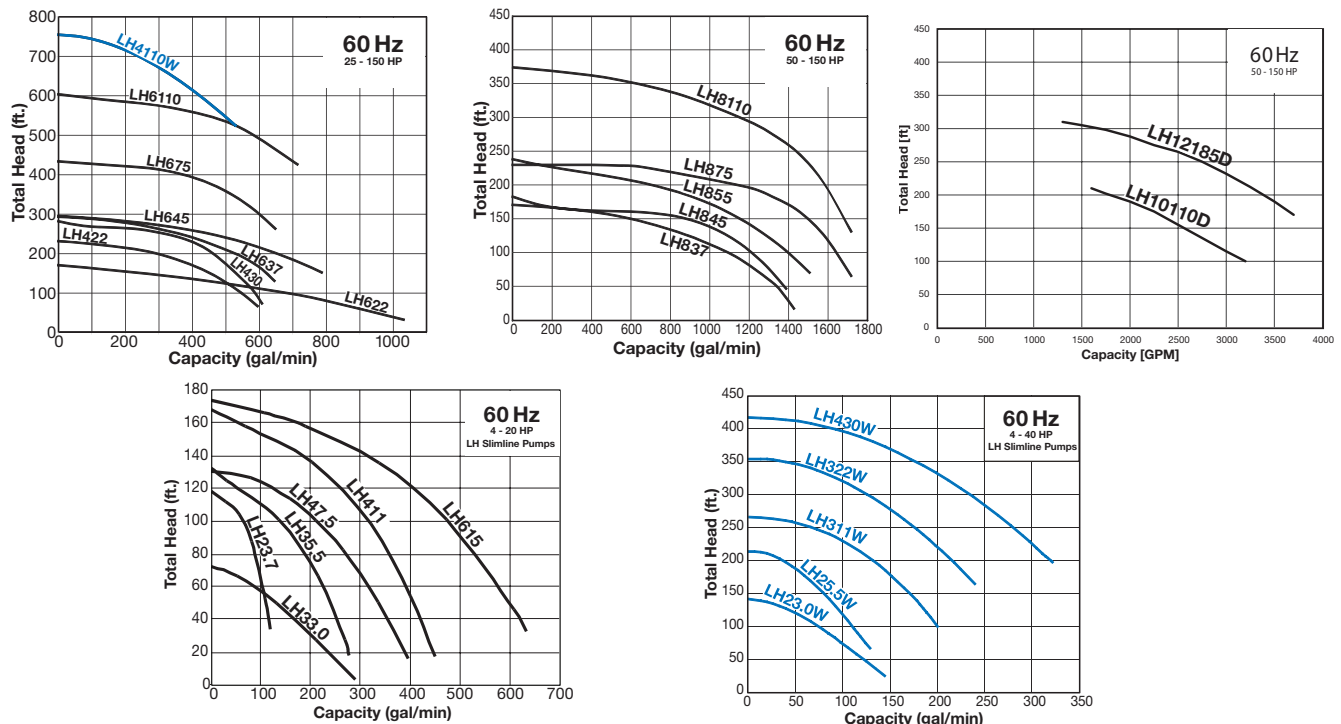

LH Series handles medium to high flows at higher heads, yet its top discharge flow-through design allows for low water level operation for extended periods. Constructed with a high chromium semi-open impeller and adjustable wear rings, our LH pumps provide increased wear resistance whether used for construction site drainage, or commercial/industrial mine dewatering, or effluent transfer.

LH-W series achieves extremely high head pressure. Our dual enclosed impellers are just one of many features engineered into these durable pumps which can help solve long distance water transfer needs.

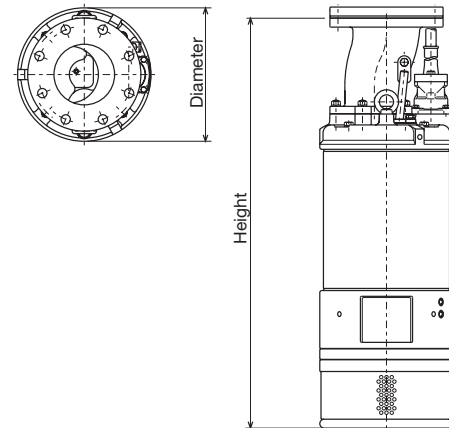

: Slimline Pumps - Pump diameter less than 15"

MODEL	MOTOR SPECIFICATIONS					Discharge Size (inch)	DIMENSION		Max. Solids Dia. (inch)	Continuous Running Water Level (in.)	Pump Weight (lbs.)	
	Output (HP)	Rated Current (A)					RPM	Diameter				Height
		208V	230V	460V	575V							
LH23.0W	4	12.3	12	6.0	4.7	3600	2	7 5/16	24 13/16	0.236	7 7/8	101
LH25.5W	7.5	22	19.2	9.6	7.7	3600	2	9 5/8	29 1/2	0.236	6 3/4	176
LH311W	15	42	37	18.5	14.5	3600	3	10 5/8	40 5/16	0.334	7 7/8	287
LH322W	30	—	—	35.5	28	3600	3	13	48 5/8	0.334	11 3/4	670
LH430W	40	—	—	48	38.5	3600	4	14 3/8	54 1/8	0.334	11 3/4	715
LH4110W	150	—	—	181	145	3600	4	24 1/2	71 7/8	0.315	15 3/4	2800

MODEL	MOTOR SPECIFICATIONS					Discharge Size (inch)	DIMENSION		Max. Solids Dia. (inch)	Continuous Running Water Level (in.)	Pump Weight (lbs.)	
	Output (HP)	Rated Current (A)					RPM	Diameter				Height
		208V	230V	460V	575V							
LH33.0	4	12.3	12	6.0	4.7	3600	3	7 5/16	25 3/8	0.236	5 7/8	93
LH23.7	5	14.6	14.6	7.3	—	3600	2	10	31 1/8	0.334	5 7/8	200
LH35.5	7.5	20.5	19.4	10	—	3600	3	10	31 1/8	0.334	5 7/8	220
LH47.5	10	28	26.5	13.5	—	3600	4	11 13/16	35 1/2	0.334	6 1/4	325
LH411	15	41	38.5	19.5	—	3600	4	11 13/16	35 1/2	0.334	6 1/4	345
LH615	20	53	48	24	19	3600	6	13	39 15/16	0.334	7 1/4	470
LH422	30	—	—	36	28.5	3600	4	16 9/16	53 1/4	0.236	9 7/8	770
LH622	30	—	—	36	28.5	3600	6	16 9/16	56	0.472	10 5/8	790
LH430	40	—	—	51	38.5	3600	4	16 9/16	53 1/4	0.236	9 7/8	780
LH637	50	—	—	58	46	3600	6	20 7/8	57	0.236	7 1/8	1090
LH837	50	—	—	58	46	3600	8	20 7/8	58 9/16	0.787	7 1/8	1090
LH645	60	—	—	67	53	3600	6	20 7/8	57	0.236	7 1/8	1120
LH845	60	—	—	67	53	3600	8	20 7/8	58 9/16	0.787	7 1/8	1120
LH855	75	—	—	87	70	3600	8	21 5/8	67 9/16	0.787	7 7/8	1810
LH675	100	—	—	113	91	3600	6	21 5/8	66	0.315	7 7/8	1910
LH875	100	—	—	113	91	3600	8	21 5/8	67 9/16	0.787	7 7/8	1910
LH6110	150	—	—	181	145	3600	6	24 1/2	74 5/16	0.394	7 7/8	2670
LH8110	150	—	—	181	145	3600	8	24 1/2	74 5/16	0.787	7 7/8	2670
LH10110D	150	—	—	166	—	3600	10	27 5/8	72 15/16	0.787	23 5/8	3190
LH12185D	250	—	—	270	—	3600	12	30 7/16	79 1/16	0.787	27 1/2	4300

KTV(E) SERIES | Lightweight, compact, durable & self-contained automatic operation



KTV2-55



KTVE33.7

Built-in Automatic Operation KTVE:

Allows a three phase pump to operate automatically in a smaller casing or sump where traditional float switches don't fit.

Material

- Impeller: -Abrasion Resistant Urethane Rubber
-Ductile Cast Iron
-High Chrome Cast Iron
- Casing: Butadiene Rubber/Natural Rubber
- Mechanical Seal: Silicon Carbide
- Motor Frame: Aluminum Alloy
- Shaft: 403 / 420 Stainless Steel
- Fasteners: 304 Stainless Steel
- Cable: PVC Sheath, Chloroprene Sheath

Features

- Lightweight, Compact Size
- Long Life and Low Maintenance
- Anti-Wicking Cable Entrance
- Dual Silicon Carbide Mechanical Seals
- Oil Lifter
- Internal Thermal Motor Protection
- Automatic Operation on KTVE Series
- Slimline design for well dewatering

Group Performance

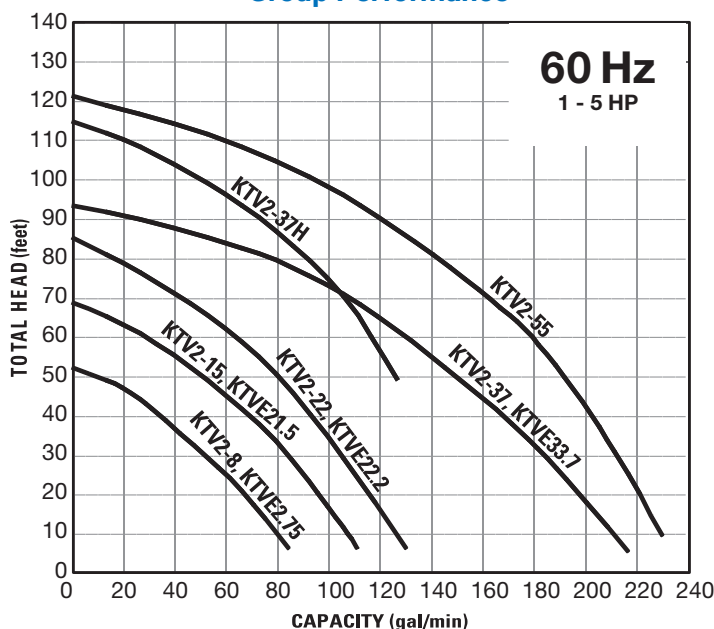

KTV series is constructed with a die cast aluminum body and elastomer pump end to reduce weight and allow easy handling. The semi-vortex impeller allows for maximum particle passage size while offering increased parts life as well as eliminating time consuming impeller adjustments.

KTVE series offers the same features as the KTV series with the added benefit of an integrally mounted electrode probe for turning the pump on and off automatically. Unnecessary dry-run is prevented to save energy and reduce wear without the need for auto control panels and cumbersome float assemblies. The pump installs and handles like a standard pump yet operates automatically by simply connecting to a manual control panel.

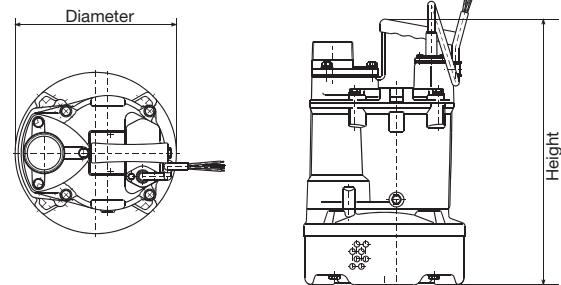

: Slimline Pumps - Pump diameter less than 15"

MODEL	MOTOR SPECIFICATIONS						Discharge Size (inch)	DIMENSIONS		Max. Solids Dia. (inch)	Continuous Running Water Level (in.)	Pump Weight (lbs.)
	Output (HP)	Rated Current (A)				RPM		Diameter	Height			
		208V	230V	460V	575V							
KTV2-8	1	3.4	3.2	1.6	1.3	3600	2	7 7/8	14 1/2	0.334	2 1/2	25
KTV2-15	2	6.0	5.4	2.7	2.1	3600	2	9 7/16	15 9/16	0.334	3 1/8	46
KTV2-22	3	8.2	7.4	3.7	2.9	3600	2	9 7/16	16 3/8	0.334	3 1/8	51
KTV2-37H	5	14.2	12.6	6.3	5.0	3600	2	11 1/4	20 1/16	0.334	3 1/2	79
KTV2-37	5	14.2	12.6	6.3	5.0	3600	3	11 1/4	20 1/16	0.334	3 1/2	79
KTV2-55	7.5	21.5	19	9.5	7.5	3600	3	11 13/16	21 7/16	0.334	3 1/2	104

MODEL	MOTOR SPECIFICATIONS						Discharge Size (inch)	DIMENSIONS		Max. Solids Dia. (inch)	Pump Starting Water Level (in.)	Pump Weight (lbs.)
	Output (HP)	Rated Current (A)				RPM		Diameter	Height			
		208V	230V	460V	575V							
KTVE2.75	1	3.4	3.2	1.7	1.3	3600	2	7 7/8	16 7/16	0.334	9 1/4	28
KTVE21.5	2	6.0	5.4	2.7	2.1	3600	2	9 7/16	16 3/4	0.334	10 1/2	48
KTVE22.2	3	8.2	7.4	3.7	2.9	3600	2	9 7/16	16 3/4	0.334	10 1/2	55
KTVE33.7	5	14.2	12.6	6.3	5.0	3600	3	11 1/4	23 1/16	0.334	12 7/8	88

KRS SERIES | High volume, extra durable pump available in a variety of sizes



KRS2-A3



KRS822

Material

Impeller:	Ductile or High Chrome
Casing:	Cast Iron
Mechanical Seal:	Silicon Carbide
Motor Frame:	Cast Iron
Shaft:	420 Stainless Steel
Fasteners:	304 Stainless Steel
Cable:	Chloroprene Sheath

Features

- High Volume Pumping
- 4 Pole, 1800 RPM Motors
- 6 Pole, 1200 RPM Motors
- Lower Impeller Tip Speeds for Longer Life
- Rugged Iron Construction
- Anti-Wicking Cable Entrance
- Dual Silicon Carbide Mechanical Seals
- Oil Lifter
- Internal Thermal Motor Protection

Group Performance: 3 - 30HP

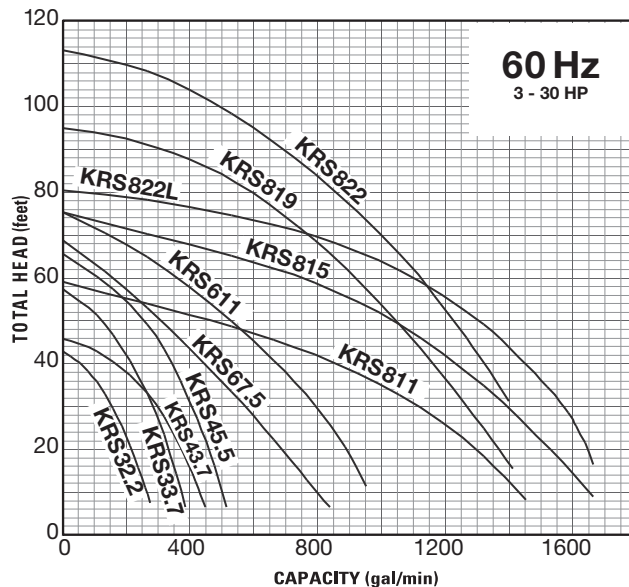

Group Performance: 30 - 50HP

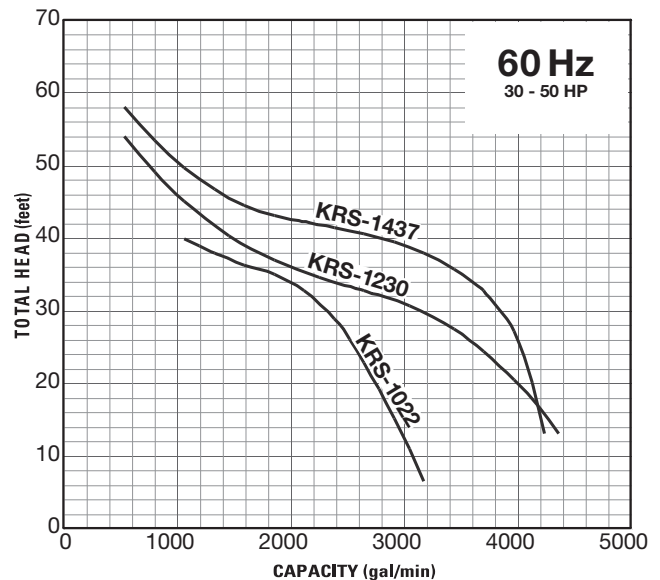

KRS series offers longer wear life on parts due to the slower impeller tip speed provided by 4-pole, 1800 RPM / 6-pole, 1200 RPM motors. Reducing impeller speed extends wear component life by at least 2 to 3 times.

The iron construction of KRS series extends the life of the pump. To prevent premature wear and failure from abrasive materials, Tsurumi's dual inside mechanical seals are completely isolated in an oil chamber with an extra lip seal to protect mechanical seals from the abrasives.

KRS series exemplifies Tsurumi's design for multi-purpose pumps to fit a wide variety of applications due to their simple construction, superb durability and high efficiency.

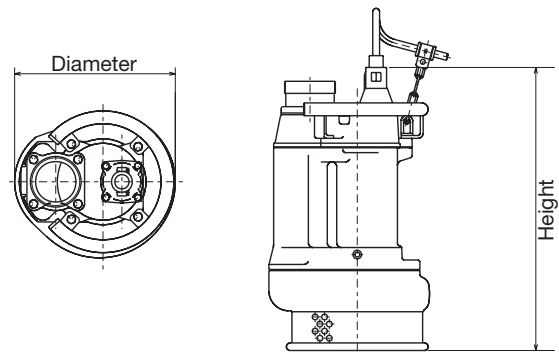

MODEL	MOTOR SPECIFICATIONS						Discharge Size (inch)	DIMENSION		Max. Solids Dia. (inch)	Continuous Running Water Level (in.)	Pump Weight (lbs.)
	Output (HP)	Rated Current (A)				RPM		Diameter	Height			
		208V	230V	460V	575V							
KRS2-A3/KRS32.2	3	9.4	8.6	4.3	3.4	1800	3	13 3/8	23 5/8	0.472	5 3/4	159
KRS2-B3/KRS33.7	5	15.0	13.8	6.9	5.5	1800	3	13 3/4	26 15/16	0.472	6 1/8	196
KRS2-A4/KRS43.7	5	15.0	13.8	6.9	5.5	1800	4	13 3/4	26 15/16	0.472	6 1/8	194
KRS2-B4/KRS45.5	7.5	21.4	19.6	9.8	7.6	1800	4	13 3/4	26 9/16	0.472	6 1/8	209
KRS2-A6/KRS67.5	10	29	26	13	10.5	1800	6	16 5/16	27 13/16	0.787	6 7/8	286
KRS2-B6/KRS611	15	42	39	19.5	14.5	1800	6	16 5/16	29 5/8	0.787	6 7/8	330
KRS2-8S/KRS811	15	42	39	19.5	14.5	1800	8	18 9/16	33 3/8	1.18	11 3/4	383
KRS815	20	57.9	55.7	27.9	22.2	1800	8	18 15/16	38 9/16	0.984	10 7/8	530
KRS819	25	—	—	33.0	26.4	1800	8	22 11/16	47 1/4	0.984	13 5/8	790
KRS822	30	—	—	38.5	30.8	1800	8	22 11/16	47 1/4	0.984	13 5/8	840
KRS822L	30	—	—	38.5	30.8	1800	8	22 11/16	47 1/4	0.984	13 5/8	840
KRS1022	30	—	—	39.6	31.5	1800	10	20 5/8	49 1/8	0.984	17 3/4	860
KRS1230	40	—	—	53.0	43.0	1200	12	26 3/8	55 1/4	1.97	18 7/8	1540
KRS1437	50	—	—	65.0	52.0	1200	14	26 3/8	55 1/4	1.97	18 7/8	1650

GSZ SERIES | High volume dewatering pumps



GSZ5-37-4



GSZ-150-4

Material

Impeller:	High Chrome Iron or Stainless Steel
Casing:	Cast Iron
Mechanical Seal:	Silicon Carbide
Motor Frame:	Cast Iron / Steel Cooling Jacket
Shaft:	420 Stainless Steel
Fasteners:	304 Stainless Steel
Cable:	Chloroprene Sheath

Features

- High Volume Pumping
- 4 Pole, 1800 RPM Motors / 6 Pole, 1200 RPM Motors
- Lower Impeller Tip Speeds for Longer Life
- Rugged Iron Construction
- Anti-Wicking Cable Entrance
- Dual Silicon Carbide Mechanical Seals
- Oil Lifter
- Internal Thermal Motor Protection
- Water Jacket for Motor Cooling

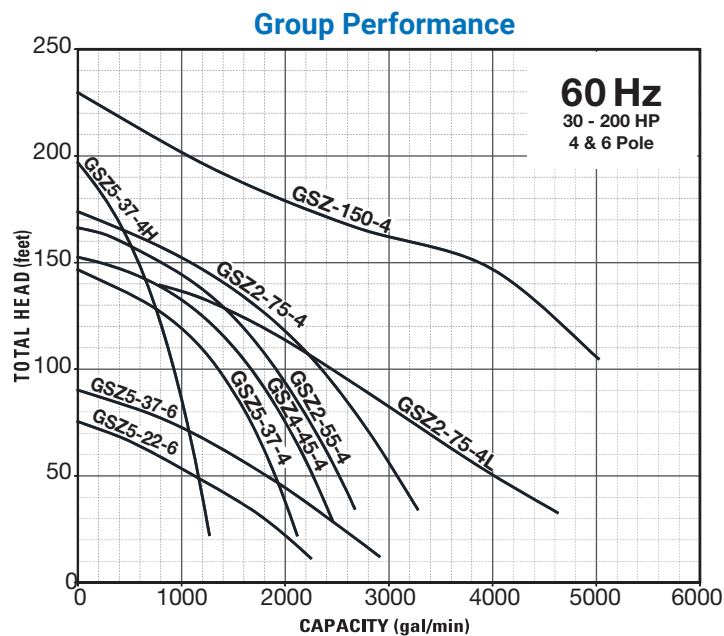

GSZ series is one of the most formidable high volume submersible dewatering pumps available. Reducing impeller speed extends wear component life by at least 2-3 times. With impeller materials of High Chrome and Stainless Steel, the GSZ series tackles the most aggressive dewatering applications. The side discharge design allows a smooth passage of abrasive materials.

Tsurumi's exclusive Seal Pressure Relief Ports further protect the mechanical seals on the 4-pole, 1800 RPM models by providing a flow path above the pump casing to allow a release of water to flow from the pump and away from the shaft. The mechanical seals remain isolated in the oil chamber above this flow path and are protected from any excessive pumping pressure or water hammer that may cause premature wear or failure of the mechanical seals in high pressure applications.

Extended operation at low water levels is made possible by utilizing a water jacket that surrounds the motor housing. A portion of the water is allowed to flow completely around the motor on its way to the side discharge. Air lock is prevented by an air-release valve at the top of the water jacket to allow air in the pump casing and water jacket to be displaced by water when the pump begins operation.

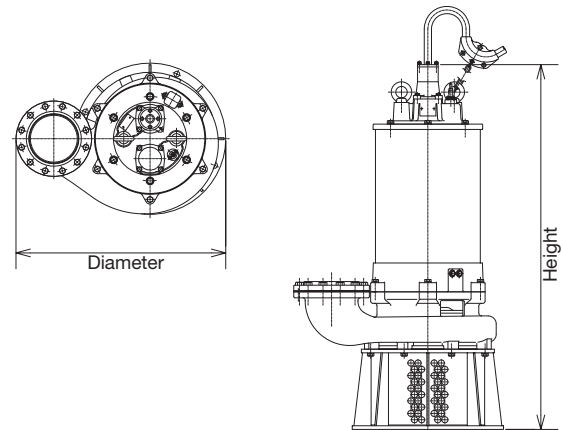

MODEL	MOTOR SPECIFICATIONS						Discharge Size (inch)	DIMENSION		Max. Solids Dia. (inch)	Continuous Running Water Level (in.)	Pump Weight (lbs.)
	Output (HP)	Rated Current (A)				RPM		Diameter	Height			
		208V	230V	460V	575V							
GSZ5-22-6	30	—	—	41	33	1200	8	38	53 9/16	1.97	13 3/4	1510
GSZ5-37-4H	50	—	—	63	49.5	1800	6	35 7/16	61 1/8	0.394	17 5/16	1310
GSZ5-37-4	50	—	—	63	49.5	1800	8	36	62 5/16	0.984	18 7/8	1250
GSZ5-37-6	50	—	—	64	51.5	1200	8	41 1/4	55 15/16	1.97	14 5/8	1750
GSZ4-45-4	60	—	—	76	63	1800	8	36	62 5/8	0.984	18 1/8	1280
GSZ2-55-4	75	—	—	97	76	1800	10	41 5/16	75 7/8	0.984	20 1/8	2430
GSZ2-75-4	100	—	—	128	101	1800	10	41 5/16	75 7/8	0.984	20 1/8	2680
GSZ2-75-4L	100	—	—	128	101	1800	10	41 5/16	77 5/8	0.984	28 3/4	2640
GSZ-150-4	200	—	—	265	-	1800	10	47 15/16	95 1/4	0.984	30 3/4	5130



Specifications

Type of Fluid: Sludge, muddy water, sandy mud

Applications

- Grit chambers, mine processing plants where light to medium abrasive solids need to stay suspended for pumping in wastewater
- Heavy abrasive construction site dewatering
- Aggregate wash down
- Ragoon / sludge pond cleanout



**Group Performance
HS, HSD, KTD and KTV**

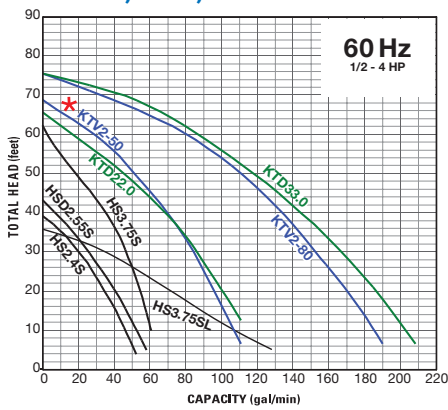

**Group Performance
KRS and GPN**

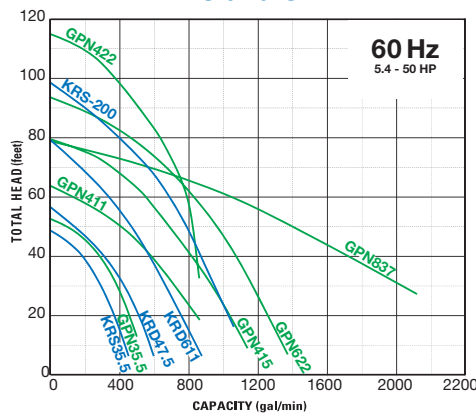

**Group Performance
GSD**

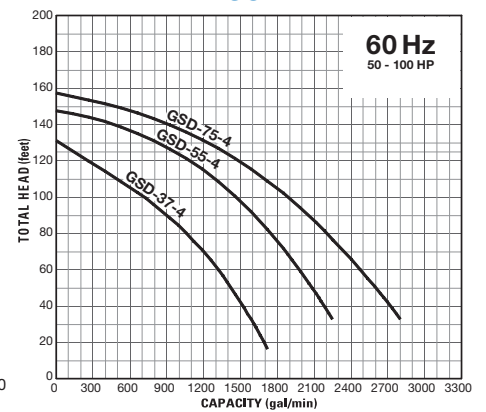



Tsurumi Agitator Pumps are equipped with hard iron adjustable wear parts and reduced tip speeds, optimal for the most aggressive applications.

Available in HS/HSD Series, NK Series, KTV Series, KTD Series, KRS Series, GPN Series, GSZ Series & GSD Series

***Additional optional protective coating available. Consult factory for recommendations.**

Agitator

Tsurumi's slurry pumps have an agitator made of abrasion resistant material. It is mounted on the shaft and rotates to create a downward current. This agitator assists the pump in suspending and transferring solids such as bentonite slurry, slime, mud, and water with high sand content.



MODEL	MOTOR SPECIFICATIONS								RPM	Discharge Size (inch)	DIMENSION		Max. Solids Dia. (inch)	Continuous Running Water Level (in.)	Pump Weight (lbs.)
	Motor Output (HP)	Phase	Rated Current (A)												
			Single phase			Three phase									
			115V	230V	208V	230V	460V	575V							
HS2.4S	1/2	Single	5.2	2.7	—	—	—	—	3600	2	10 1/16	12 15/16	0.276	3 1/2	30
HS3.75S	1	Single	9.7	4.9	—	—	—	—	3600	3	12 7/16	15 5/16	0.276	3 1/2	50
HS3.75SL	1	Single	9.7	—	—	4.9	—	—	3600	3	11 5/16	16 3/4	0.276	4 3/4	50
HSD2.55S	3/4	Single	7.3	3.7	—	—	—	—	3600	2	10 3/8	15 3/8	0.393	4 1/8	38
KTV2-50	2.7	Three	—	—	7	6.4	3.2	2.6	3600	2	9 13/16	17 7/8	0.334	4 3/4	55
KTV2-80	4	Three	—	—	11.6	10.6	5.3	4.2	3600	3	11 5/8	21 5/8	0.334	5 1/8	84
KTD22.0	2.7	Three	—	—	8.7*	8.2	4.1	3.3	3600	2	9 1/4	23 3/16	0.394	5 1/2	86
KTD33.0	4	Three	—	—	12*	11.4	5.9	4.5	3600	3	11 11/16	25 3/4	0.394	6 1/4	145
KRS2-80/KRD35.5	7.5	Three	—	—	18*	16.5	8.5	6.5	1800	3	13 3/4	30 11/16	1.18	10 3/8	231
KRS2-100/KRD47.5	8	Three	—	—	25*	23	11.5	9.2	1800	4	16 3/8	30 7/8	1.18	10 5/8	315
KRS2-150/KRD61.1	12	Three	—	—	36*	33	16.5	13.2	1800	6	16 3/8	33	1.18	10 5/8	357
KRS200	30	Three	—	—	—	—	30	24	1800	8	22 11/16	44 7/8	1.18	11 1/4	840
GPN35.5	7.5	Three	—	—	21.4	20*	9.3	7.6	1800	3	19 3/16	31 5/16	1.18	11 3/8	319
GPN411	15	Three	—	—	42	39*	18.6	14.5	1800	4	24 5/16	34 5/8	1.18	12 3/8	478
GPN415	20	Three	—	—	55	52*	24	22	1800	4	24 5/16	34 5/8	1.18	12 3/8	485
GPN422	30	Three	—	—	—	—	36.5	29.5	1800	4	28 9/16	43 3/8	1.18	11 3/4	915
GPN622	30	Three	—	—	—	—	36.5	29.5	1800	6	28 9/16	43 3/8	1.18	11 3/4	915
GPN837	50	Three	—	—	—	—	64	51.5	1800	8	39 15/16	63 1/4	1.81	22	1760
GSD-37-4	50	Three	—	—	—	—	63	49.5	1800	8	36	62 5/16	0.984	18 7/8	1290
GSD-55-4	75	Three	—	—	—	—	97	76	1800	10	41 5/16	75 7/8	0.984	20 1/8	2440
GSD-75-4	100	Three	—	—	—	—	128	101	1800	10	41 5/16	75 7/8	0.984	20 1/8	2690

* Dual Voltage

SFQ • SQ | Corrosion resistant stainless steel pumps



80SFQ211



50SQ2-2.4S

Material

Model	SFQ	SQ
Impeller:	316 Stainless Steel	Resin
Casing:	316 Stainless Steel	304 SS & Rubber
Mechanical Seal:	Silicon Carbide	Silicon Carbide
Motor Frame:	316 Stainless Steel	304 Stainless Steel
Shaft:	316 Stainless Steel	304 Stainless Steel
Fasteners:	316 Stainless Steel	304 Stainless Steel
Cable:	PVC Sheath Chloroprene Sheath	PVC Sheath

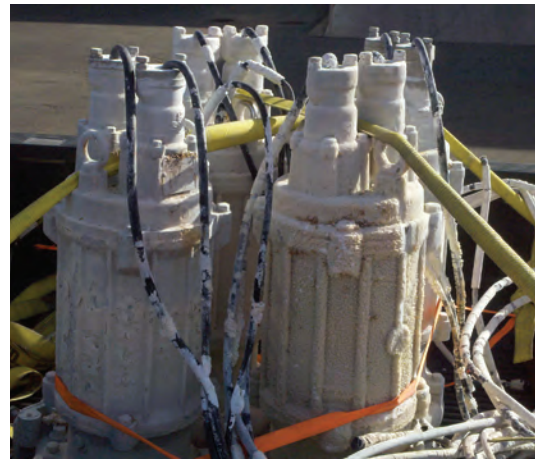

Group Performance: SFQ

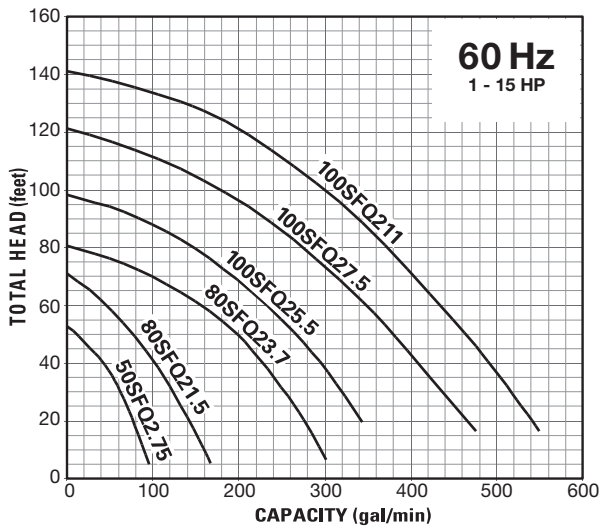

Group Performance: SQ

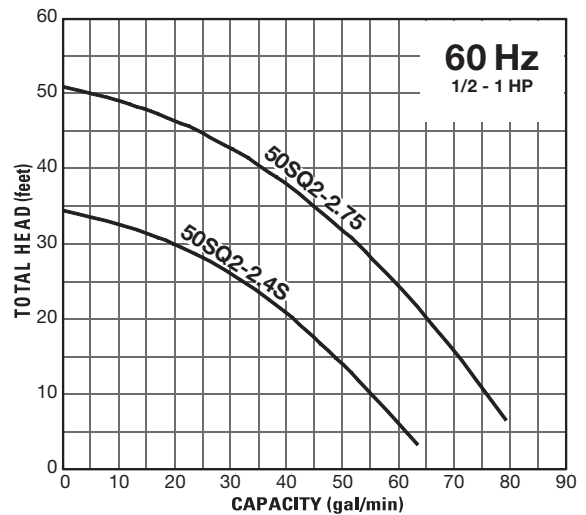

■ Features

SFQ Series

- All wetted components are 316 Stainless Steel
- Viton elastomers
- Dual inside mechanical seals with Silicon Carbide faces, operate in an oil filled chamber
- Built in motor protector
- Semi-open, 316 stainless steel impeller
- Seal pressure relief system (7.5 - 15HP)
- Optional 316 SS Guide rail system is available for models from 7.5 - 15hp.

SQ Series

- Constructed of a combination of 304 and 316 stainless steel materials, Nitrile Butadiene Rubber and special resin to stand up to corrosion
- Sporting a new and lighter structural design
- Non-toxic white mineral oil used to lubricate silicon carbide mechanical seals
- Motor protector protects against overheating and run-dry
- Designed to fit into an 8-inch pipe

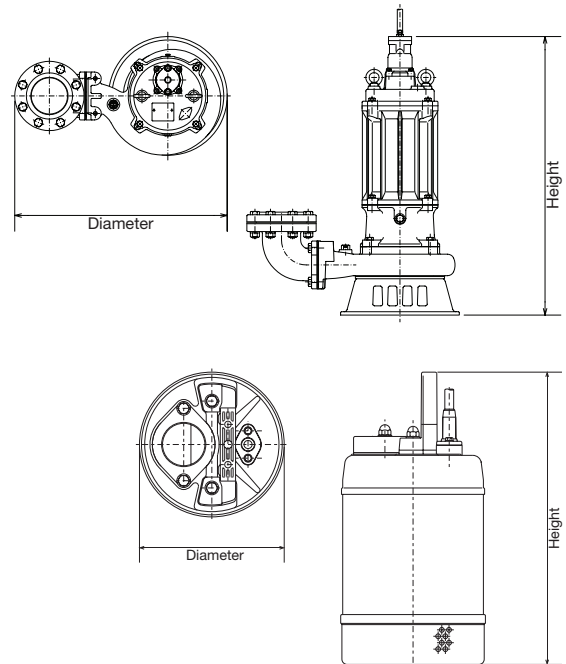
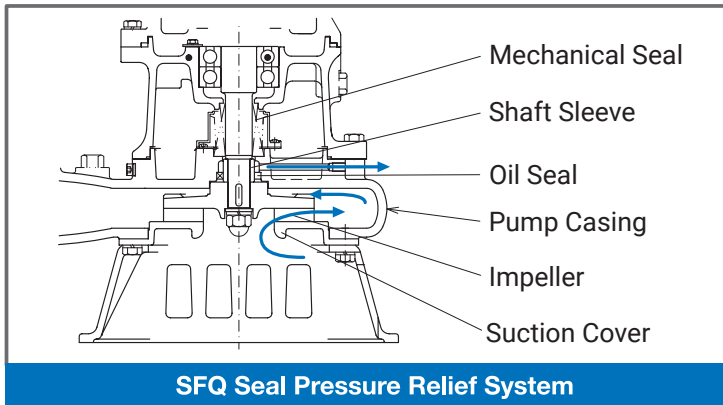

MODEL	MOTOR SPECIFICATIONS								Discharge Size (inch)	DIMENSION		Max. Solids Dia. (inch)	Continuous Running Water Level (in.)	Pump Weight (lbs.)	
	Motor Output (HP)	Phase	Rated Current (A)							RPM	Diameter (in.)				Height (in.)
			Single phase		Three phase										
			115V	230V	208V	230V	460V	575V							
50SFQ2.75	1	Three	—	—	3.5	3.1	1.6	1.4	3600	2	9 15/16	15 11/16	0.236	14 1/8	49
80SFQ21.5	2	Three	—	—	6.9	6.7	3.4	2.7	3600	3	12 15/16	19 1/16	0.236	16 3/8	79
80SFQ23.7	5	Three	—	—	13.8	12.8	6.4	5	3600	3	14 1/8	21 5/16	0.591	19 1/2	115
100SFQ25.5	7.5	Three	—	—	19.3	18.2	9.4	7.5	3600	4	25 3/8	33 1/4	0.787	27 1/8	278
100SFQ27.5	10	Three	—	—	26.0	24.0	12.2	9.5	3600	4	25 3/8	33 1/4	0.787	27 1/8	286
100SFQ211	15	Three	—	—	37.0	35.2	17.6	13.9	3600	4	25 3/8	35 1/8	0.906	28	320

MODEL	MOTOR SPECIFICATIONS								Discharge Size (inch)	DIMENSION		Max. Solids Dia. (inch)	Continuous Running Water Level (in.)	Pump Weight (lbs.)	
	Motor Output (HP)	Phase	Rated Current (A)							RPM	Diameter (in.)				Height (in.)
			Single phase		Three phase										
			115V	230V	208V	230V	460V	575V							
50SQ2-2.4S	1/2	Single	5.1	2.9	—	—	—	—	3600	2	7 1/16	14 7/16	0.236	2 3/8	27
50SQ2-2.75	1	Three	—	—	3.4	3.5	2.0	1.5	3600	2	7 1/16	15 3/16	0.236	2 3/8	31

LB • LBT | Portable slimline dewatering pump



Material

Model	LB-480 / LB(T)-800	LB(T)-1500
Impeller:	Semi-Vortex	Semi-Open
Impeller Materials:	Urethane Rubber	High Chrome Cast Iron
Volute Casing Materials:	LB-480 - Ethylene Propylene Rubber LB(T)-800 - Butadiene Rubber & Natural Rubber LB(T)-1500 - Butadiene Rubber, Natural Rubber & Steel	
Wear Plate Materials:	LB-480 & LB(T)-800 - Urethane Propylene Rubber LB(T)-1500 - Butadiene Rubber & Natural Rubber	
Shaft Seal:	Double inside mechanical seal with silicone carbide	

Features

All Models:

- Built with durable yet light weight materials
- Built-in Motor Protector
- Double Inside Mechanical Seal with Silicon Carbide faces
- Oil Lifter provides lubrication of the seal faces
- Single-phase is available in automatic operation

LB(T)-1500 only:

- High Chrome Iron Semi-Open Impeller
- Synthetic Rubber Pump Casing
- Optional 2" discharge available

Group Performance

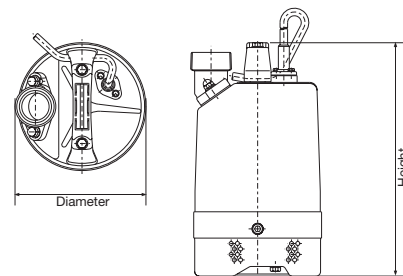
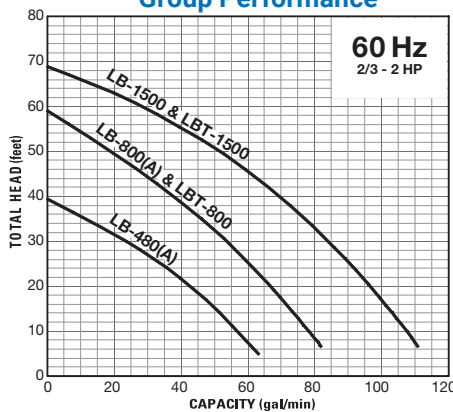

MODEL	MOTOR SPECIFICATIONS								Discharge Size (inch)	DIMENSION		Max. Solids Dia. (inch)	Continuous Running Water Level (in.)	Pump Weight (lbs.)	
	Motor Output (HP)	Phase	Rated Current (A)							RPM	Diameter (in.)				Height (in.)
			Single phase		Three phase										
			115V	230V	208V	230V	460V	575V							
LB-480	2/3	Single	5.9	3	—	—	—	—	3600	2	7 11/16	11 1/4	0.236	2	28
LB-800	1	Single	10.5	5.2	—	—	—	—	3600	2	7 9/16	13 7/16	0.236	2	38
LBT-800	1	Three	—	—	3.6	3.7	1.7	1.4	3600	2	7 9/16	13 7/16	0.236	2	38
LB-1500	2	Single	26.2	13.2	—	—	—	—	3600	3	7 3/8	23 5/16	0.236	3 1/8	88
LBT-1500	2	Three	—	—	7.2	8.0	4.0	3.0	3600	3	7 3/8	23 5/16	0.236	3 1/8	88

EPT4 | Heavy Duty Trailer Mount / Skid Mount Trash Pump



EPT4-150: Trailer mount



EPT4-150Q: Sound attenuated trailer mount



EPT4-150S: Skid mount opened

Material

Impeller Type:	Fully Enclosed
Impeller Material:	Cast Iron
Volute Casing Material:	Cast Iron
Wear Plate / Ring Material:	Cast Iron
Pump Casing Material:	Cast Iron
Shaft Seal:	Tungsten Carbide Silicon Carbide

Features

- Prime assisted pump utilizes venturi system for priming
- Diesel engine (Water Cooled)
- Passes 3-inch spherical solids
- Mechanical seal with tungsten and silicon carbide seal faces, viton elastomers, 303 stainless steel hardware and spring. Seal system designed for dry running
- D.O.T. Approved heavy duty road trailer
- EPT4-150Q: Capable of quiet operation

Group Performance

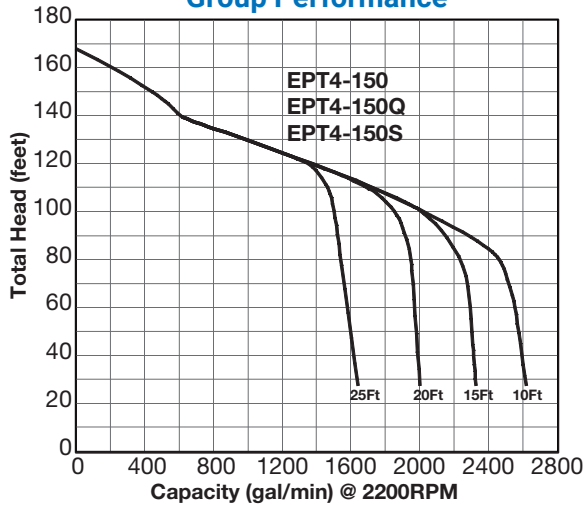

MODEL	PUMP SPECIFICATIONS				ENGINE SPECIFICATIONS				DIMENSIONS			
	Discharge Size (in.)	Maximum Capacity (GPM)	Maximum Head (ft.)	Engine	Output (HP)	Fuel	Fuel Tank Capacity (Gal.)	Starting Method	Length (in.)	Width (in.)	Height (in.)	Weight (lbs.)
EPT4-150 Standard	6" ANSI Flange	Consult Factory	Consult Factory	Diesel	Consult Factory	Diesel	80	Electric 12V	133	65	77	Consult Factory
EPT4-150Q Sound Attenuated							80		161 1/2	76 1/8	79 13/16	
EPT4-150S Skid Mount							120		100	42	49 1/2	

FOR SPECIAL PUMPING | Submersible Seawater-Resistant Dewatering Pumps

Seawater Resistant Kit

Tsurumi's standard pumps can be combined with a seawater-resistant kit (optional) that adds a galvanic anode and seawater-resistant special cast iron impeller, and enables about two years of service. (The service period depends on operating conditions.)

- Galvanic Anodes (with Fittings, Seal Putty)
- Seawater-Resistant Special Cast Iron Impeller
- 304 Stainless Steel Eye Bolts*
* Applicable only with models having steel eye bolts



KTZ33.7

LH311W

KRS815

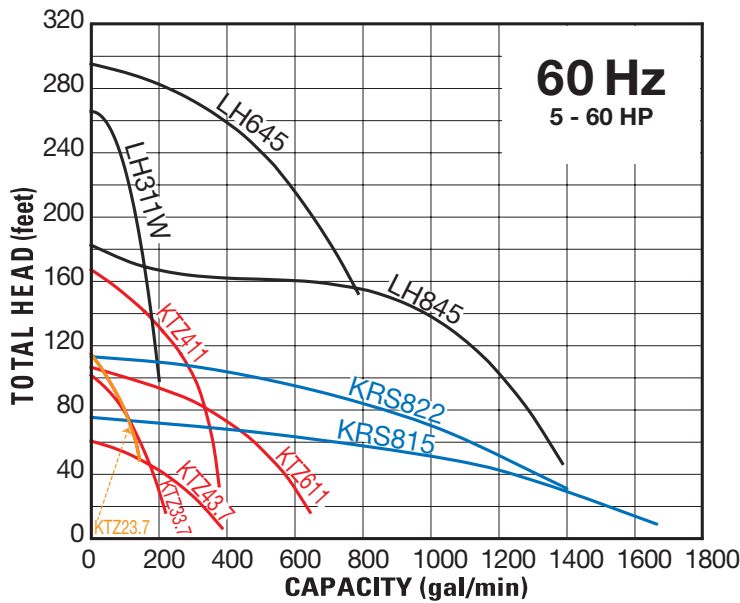

The **galvanic anode** is an electrolytic protective measure used with metals of differing corrosive potentials. Metals of a potential lower (aluminium and zinc) than the pump body (cast iron and steel) are brought into contact with the body via the galvanic anodes and allowed to corrode in order to protect the body. However, the full effect cannot be obtained unless the anodes are installed in the proper positions.

Tsurumi mainly utilizes aluminium because of its superior anticorrosive performance per unit weight, while utilizing zinc for only the strainer stand that is liable to be worn by water current. Since the galvanic anodes are worn by corrosion, they need to be replaced every two years. They can be replaced easily and used immediately after replacement.

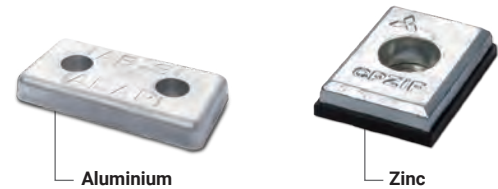

Aluminium

Zinc

Corrosion Test (in seawater, 1 year)

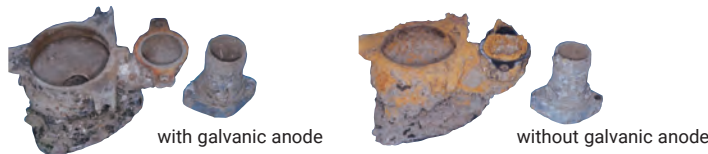

with galvanic anode

without galvanic anode

MODEL	MOTOR SPECIFICATIONS					Discharge Size (inch)	DIMENSION		Max. Solids Dia. (inch)	Continuous Running Water Level (in.)	Pump Weight (lbs.)	
	Output (HP)	Rated Current (A)					RPM	Diameter				Height
		208V	230V	460V	575V							
KTZ23.7	5	15	13.6	6.8	5.3	3600	2	11 1/8	26 1/4	0.334	5 7/8	137
KTZ43.7	5	15	13.6	6.8	5.3	3600	4	11 1/8	27 1/16	0.334	5 7/8	137
KTZ411	15	39.8	37.4	18.6	14.9	3600	4	14 3/4	32 15/16	0.472	7 1/2	293
KTZ611	15	39.8	37.4	18.6	14.9	3600	6	14 3/4	33 11/16	0.787	7 1/2	295
LH645	60	—	—	67	53	3600	6	20 7/8	57	0.236	7 1/8	780
LH845	60	—	—	67	53	3600	8	20 7/8	58 9/16	0.787	7 1/8	1120
LH311W	15	42	37	18.5	14.5	3600	3	10 5/8	40 5/16	0.334	7 7/8	287
KRS815	20	57.9	55.7	27.9	22.2	1800	8	18 15/16	38 9/16	0.984	10 7/8	530
KRS822	30	—	—	38.5	30.8	1800	8	22 11/16	47 1/4	0.984	13 5/8	840

FOR SPECIAL PUMPING | Tandem Operation - LH • LHW



Tandem operation is an operation method that connects two pumps of the same model in series. This provides ultra high head at the same flow rate in comparison with that of a single pump. The principle of tandem operation is the same as that with multistage pumps. The LH and LHW series pumps adopt the center flange construction to align the discharge pipe with the cylindrical pump center axis.* Connecting the pumps in series with the tandem connector can provide higher pump head without affecting the advantage of the slim design. At construction sites, there are many cases where a higher pump head is required as construction work progresses. In such cases, the addition of a tandem pump may meet the required pump head, instead of using a new pump.

* Available as an option for separately purchased LH33.0 and LH23.0W.

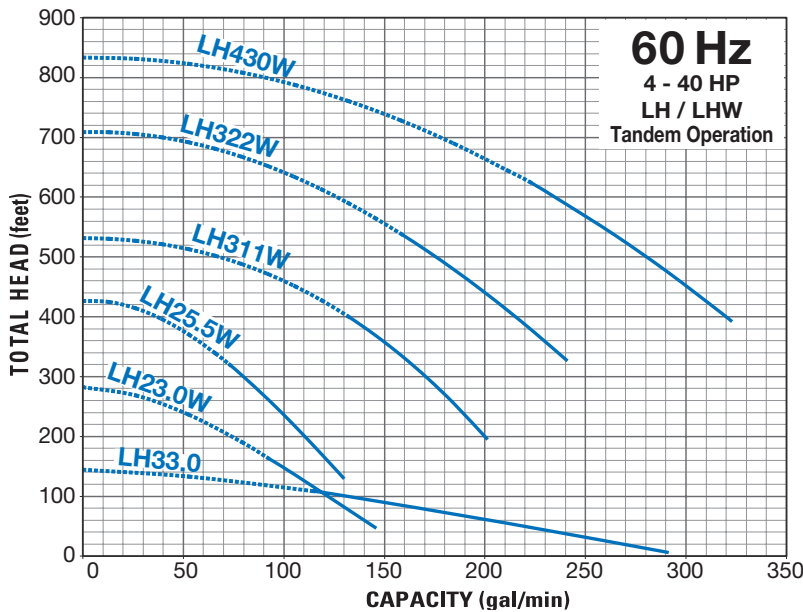

REMARKS:

The intermediate connection pipe is not required in the range indicated as a bold line on curves. If the required total head exceeds the maximum head of the pump without an intermediate connection pipe (indicated as dashed line), an intermediate connection pipe of a length corresponding to the excess amount or more is required.*

*Consult factory for design assistance

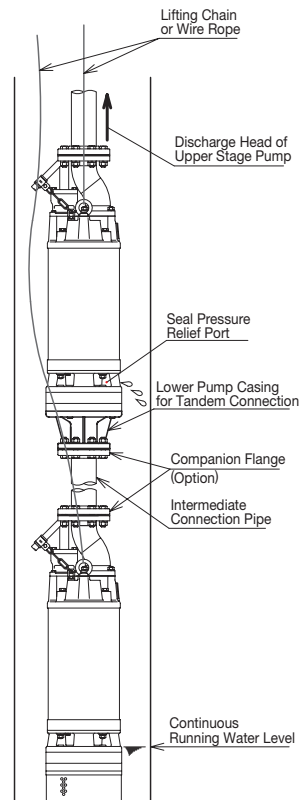

MODEL	MOTOR SPECIFICATIONS					Discharge Size (inch)	DIMENSION		Max. Solids Dia. (inch)	Continuous Running Water Level (in.)	Pump Weight (lbs.)	
	Output (HP)	Rated Current (A)					Diameter	Height				
	208V	230V	460V	575V	RPM							
LH33.0	4	12.3*	12	6.0	4.7	3600	3	7 5/16	25 3/8	0.236	5 7/8	93
LH23.0W	4	12.3*	12	6.0	4.7	3600	2	7 5/16	24 13/16	0.236	7 7/8	101
LH25.5W	7.5	22	19.2	9.6	7.7	3600	2	9 5/8	29 1/2	0.236	6 3/4	176
LH311W	15	42	37	18.5	14.5	3600	3	10 5/8	40 5/16	0.334	7 7/8	287
LH322W	30	—	—	35.5	28	3600	3	13	48 5/8	0.334	11 3/4	670
LH430W	40	—	—	48	38.5	3600	4	14 3/8	54 1/8	0.334	11 3/4	715

* 208 & 230V same motor

FOR SPECIAL PUMPING | LH-14 / LHW-14 STAINLESS STEEL DEWATERING PUMP



LH-14 / LHW-14 series are submersible pumps designed for handling aggressive and corrosive liquids. All wetted parts are made of 316 Stainless Steel, enabling it to withstand demanding conditions found in construction, aggregate and mining applications. Because of its slim design, LH-14 / LHW-14 Series pump can be installed in a well casing for deep well dewatering. The center flange construction ensures stable installation, even if it is fixed by the discharge pipe. The pump incorporates seal pressure relief ports that prevent the pumping pressure from applying to the shaft seal.

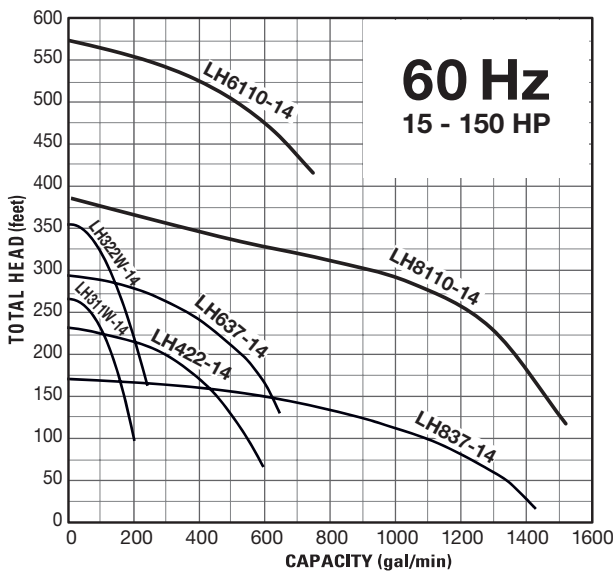

pH Values and Corrosion Resistance of Tsurumi Pumps

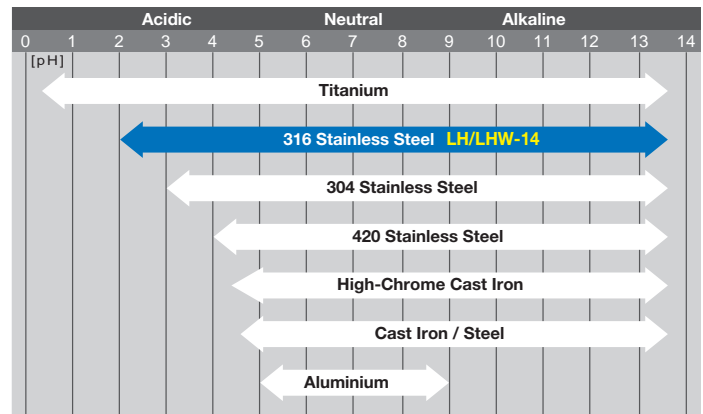

The above data is a rough indication for sulfuric acid (H₂SO₄) and sodium hydroxide (NaOH). Metals are affected by the type of acid/alkali, seal material, painting and abrasive environment.

- **Stainless Steel Casting**
- **High Head**
- **Corrosion-Resistant**

Special Rubber Parts Made of Viton Elastomer

Rubber parts of the mechanical seal, oil seal, O-ring and packings are made of viton elastomer which provides higher resistance to heat and chemicals.

MODEL	MOTOR SPECIFICATIONS					Discharge Size (inch)	DIMENSION		Max. Solids Dia. (inch)	Continuous Running Water Level (in.)	Pump Weight (lbs.)	
	Output (HP)	Rated Current (A)					RPM	Diameter				Height
		208V	230V	460V	575V							
LH422-14	30	—	—	36	28.5	3600	4	16 9/16	53 1/4	0.236	9 7/8	815
LH637-14	50	—	—	58	46	3600	6	20 7/8	57	0.236	7 1/8	1190
LH837-14	50	—	—	58	46	3600	8	20 7/8	57	0.787	7 1/8	1190
LH311W-14	15	42	37	18.5	14.5	3600	3	13	46 5/8	0.334	7 7/8	705
LH322W-14	30	—	—	35.5	28	3600	3	13	50 3/16	0.334	11 3/4	750
LH6110-14	150	—	—	157	145	3600	3	23 5/16	74 5/16	0.394	7 7/8	2970
LH8110-14	150	—	—	157	145	3600	3	23 5/16	74 5/16	0.787	7 7/8	2970

FOR SPECIAL PUMPING | BARGE SYSTEM & FLOTATION MODULES



BARGE SYSTEM

Floating barges can be used with any Tsurumi dewatering pump to allow dewatering from quarries, pits, and other sites. Barges allow a pump to operate close to the surface of the water, preventing it from pumping settled abrasives or solids. The versatility of the system allows for both the barge and the pump to be adjusted so water can be pumped down to the lowest level in cases of uneven terrain.

The barges are constructed with polyethylene float sections and welded steel sections to provide a durable platform for harsh outdoor environments. Pumps can be hung from a center beam in the central opening.



Barge Dimensions (ft.)	Max. Capacity
6 x 6	296 lbs
8 x 8 with platform	2000 lbs
8 x 8	3100 lbs
10 x 10 with platform	4550 lbs
10 x 10	5750 lbs

Consult factory for additional options and materials.

FLOTATION MODULES: TFM

The Concept

The pump flotation modules have been developed to provide a light-weight and cost-effective alternative to the traditional steel pontoon.

Installation

The pump and integral module can be simply installed by use of a central lifting attachment. Once in the water, the module can be towed by boat, if required, and secured in position by anchor or guide ropes. The float module remains visible above the water surface for easy recovery.

Applications

- Mine dewatering
- Tailing dams
- Underground dams
- Sewage treatment
- Aeration ponds
- Floating foundation displays
- Construction site dewatering

Design Features

- Compact and lightweight
- Easily mounted to pumps on site
- Lifting points for easy installation
- Easy to transport as an integral unit
- Foam filled to prevent sinking

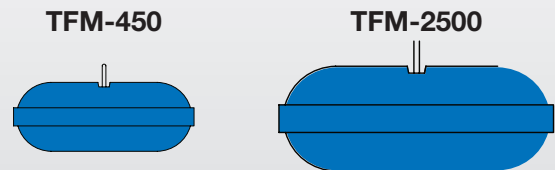

	TFM-450	TFM-2500
Float dimensions (inches - approximate)	39 x 39 x 18	71 x 71 x 30
Pump mounting bracket	Stainless steel	Galvanized steel
Weight (approximate) including brackets	150lbs. to 172lbs.	567lbs. to 661lbs.
Maximum Pump Weight	450lbs.	2500lbs.

TSURUMI PUMP[®] ACCESSORIES

CONTROL PANELS - Automatic / Manual, VFD & Soft Start Control Panels

■ Automatic Control Panels

- UL Listed Nema 4X Fiberglass Enclosure
- HOA Selector Switch
- IEC Rated Magnetic Contactor
- Field Adjustable Overload Protection
- Includes (2) 50" Mechanical Floats



■ Manual Control Panels

- Nema 4X Fiberglass Enclosure
- UL Listed
- Hand/Off Lockable Selector Switch
- IEC Rated Magnetic Contactor
- Field Adjustable Overload Protection



■ VFD and Soft Start Control Panels

- Constant Pressure
- Constant Level
- Pace FLOW
- UL Listed
- Field Adjustable Overload Protection

Available Options Include:

- Line Reactor
- Load Reactor
- Seal Leak Protection
- Lightning Protection
- Ground-Ground Check Protection
- Elapsed Time meter
- Mechanical Floats
- Liquid Level Probes
- SCADA monitoring



For Sales, Service, and Specifications, call:

1 - 8 1 9 - 7 9 7 - 3 3 0 0

 **TSURUMI PUMP**[®]
BUILT FOR WORK[®]

Technosub

1156 avenue Larivière
Rouyn-Noranda, Québec, CANADA, J9X 4K8

Tel: 1-819-797-3300

info@technosub.net

Your Dealer